



# LP4A USER MANUAL

<LP423A / LP433A>



User Manual : LP4 series

Issue Date : 2020/11/18

Version 4.2

# Declaration

The content of this manual is subject to change without prior notice and cannot be altered without written permission obtained from Wincode Technology Co., Ltd (hereinafter referred to as "Wincode"). No part of this manual may be reproduced or transmitted in any form by any means. This manual includes the installation instruction and detailed description of possible questions in the operation. Wincode has reserved the right to improve product including technology, components, software and hardware.

# Copyright

The Copyright of this manual is belonged to Wincode  
Ver4.0,08.2018.  
Printed in Taiwan

# Trademark



Our registered trademark: 

# Compliances

CE Class A

FCC Part 15, Class A

CB

Comply with RoHS regulation

**警告**

此为 A 级产品，在生活环境中，该产品可能会造成无线电干扰。在这种情况下，可能需要用户对干扰采取切实可行的措施。

# Safety Instructions

Please read the following instructions carefully.

1. Install printer on the flat and stable place. To avoid printer exposed in the high temperature or high humidity or polluted place.
2. Do not disassemble the printer and adapter under any circumstances.
3. Please check the voltage before printer is connected with power outlet; If printer is deemed to idle for a long time, please pull out the power cord to avoid voltage instability to cause printer damage.
4. If printer gets water or conductive material, please shut off the power immediately to ensure the safety of personnel and equipment.
5. To avoid printer to start printing while there is no label paper installed; otherwise the print head and platen roller would be damaged.
6. The print head is a thermal part, please do not touch it or its peripherals during printing or after printing.
7. Shut down the printer when connecting or disconnecting interfaces to avoid any damage happened.
8. Please choose designated adapter model of Wincode to connect printer accordingly.

# Contents

<b>DECLARATION</b> .....	- 1 -
<b>SAFETY INSTRUCTIONS</b> .....	- 2 -
<b>1. PRODUCT INTRODUCTION</b> .....	- 5 -
1.1 UNPACKING AND CHECKING .....	- 6 -
1.2 APPEARANCE .....	- 7 -
<b>2. SETUP</b> .....	- 9 -
2.1 SETTING UP THE PRINTER .....	- 9 -
2.2 RIBBON LOADING .....	- 10 -
2.3 LABEL LOADING .....	- 16 -
2.4 REAL TIME CLOCK BATTERY INSTALLATION.....	- 19 -
2.5 CUTTER INSTALLATION (OPTIONAL) .....	- 20 -
2.5.1 Label Installation.....	- 22 -
2.6 PEELER INSTALLATION (OPTIONAL) .....	- 23 -
2.6.1 Label Installation.....	- 26 -
<b>3. DRIVER INSTALLATION</b> .....	- 27 -
3.1 PRINTER INSTALLATION.....	- 28 -
3.2 INSTALL DRIVER WITH “ADD A PRINTER” IN MICROSOFT .....	- 32 -
3.2.1 Printer Installation .....	- 33 -
3.3 PRINTING SETUP (DRIVER SETUP) .....	- 40 -
3.3.1 Page Setup .....	- 40 -
3.3.2 Media Settings .....	- 41 -
3.3.3 Sensor Calibration.....	- 43 -
3.3.4 Options.....	- 44 -
3.3.5 Image Processing .....	- 47 -
3.3.6 Tools .....	- 48 -
3.3.7 About .....	- 49 -
<b>4. WINLABEL TOOL SUITE</b> .....	- 50 -
4.1 SOFTWARE INTRODUCTION .....	- 50 -
4.2 SOFTWARE INSTALLATION .....	- 51 -
4.3 WINLABEL LABEL EDITING SOFTWARE .....	- 52 -
4.4 UPDATE SETTINGS AND UPDATE CHECK .....	- 53 -
4.5 FIRMWARE UPDATE TOOL .....	- 54 -
<b>5. PRINTER UTILITY</b> .....	- 55 -
5.1 PRINTING SUMMARY .....	- 57 -
5.2 SETTINGS .....	- 58 -
5.3 FILE MANAGEMENT .....	- 61 -
5.4 SEND COMMAND.....	- 62 -



- 6.LED INDICATORS AND BUTTON EXPLANATION ..... - 63 -**
  - 6.1 LED AND BUTTON DESCRIPTION ..... - 64 -
- 7.LCD MENU DESCRIPTION ..... - 65 -**
  - 7.1 PROGRAM ..... - 66 -
  - 7.2 SETTING ..... - 67 -
  - 7.3 DEVICE ..... - 68 -
  - 7.4 COMMUNICATION PORT ..... - 69 -
  - 7.5 FILE SYSTEM ..... - 70 -
  - 7.6 INFORMATION ..... - 70 -
  - 7.7 UPGRADE ..... - 71 -
- 8.STANDALONE PRINTING ..... - 72 -**
  - 8.1 FEATURE ..... - 72 -
  - 8.2 USER INTERFACE ..... - 73 -
  - 8.3 HARDWARE NOTICE ..... - 75 -
    - 8.3.1 Equipment Introduction ..... - 75 -*
    - 8.3.2 Printer Ports Introduction..... - 76 -*
    - 8.3.3 Printer RS-232 pin assignment ..... - 76 -*
    - 8.3.4 Printer serial port with electronic scales pin assignment..... - 77 -*
    - 8.3.5 Printer serial port with RS-232 scanner pin assignment ..... - 77 -*
    - 8.3.6 External device ..... - 78 -*
    - 8.3.7 How to contact printer electronic scales ..... - 79 -*
  - 8.4 OPERATING PROCEDURES..... - 81 -
    - 8.4.1 Standalone operating procedures diagram ..... - 81 -*
    - 8.4.2 How to make a standalone file..... - 82 -*
  - 8.5 HOW TO DOWNLOAD THE FILE TO THE PRINTER ..... - 93 -
  - 8.6 HOW TO EXECUTE STANDALONE FILE ..... - 99 -
  - 8.7 ACTUAL CASES USING STANDALONE OPERATION ..... - 101 -
- 9.GENERAL KEYPAD CORRESPONDENCE ..... - 102 -**
- 10. NUMERIC KEYPAD CORRESPONDENCE ..... - 103 -**
- 11. MAINTENANCE..... - 104 -**
- 12. APPENDIX – LP4A SERIES SPECIFICATION ..... - 105 -**

## 1. Product Introduction

Thank you for purchasing Wincode's LP4A series label printer, this desktop label printer with reasonable price has reliable quality to provide user highly-efficient printing performance. The LP4 series printer not only can print label in text or graphic formats, but owns basic function and convenient operation interface.

In addition, LP4N series label printer with elegant bright black enclosure has cover open buffer design to avoid hand clamped in operation; The maximum 5" outside diameter label loading space; Dual ribbon loading design enables user to use 100m or 300m ribbon; It is also equipped 32 bit processor with highly efficient relevant configurations to make printing action smoothly and clearly so it can be applied in the different fields such as retailing, health care, manufacturing, logistics, warehousing and so on.

The bundled label design program as "WinLabel" provides completed label design tools and barcode resource for user to design ideal label format; Free database function can be connected with Excel, Access, Text file...etc. and get required information in the specified position of label. Standalone function can support advanced models LP4A series to produce standalone format label.

## 1.1 Unpacking and checking

Unpacking the package, and refer to the below packing list to check whether any part is damaged or missing in transit. If this incident has been happened, please contact with local dealer or distributor for further assistance.



Label Printer

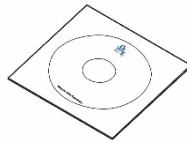

CD Disc(Optional)



Quick Installation Guide

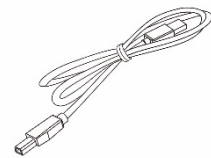

USB Cable



Adapter

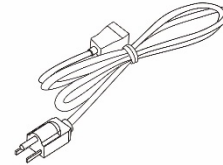

Power Cord

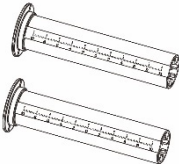
Ribbon Supply Spindle  
Ribbon Take-up Spindle

Empty Paper Core (1" core)

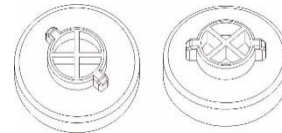

0.5" ribbon cap

## 1.2 Appearance

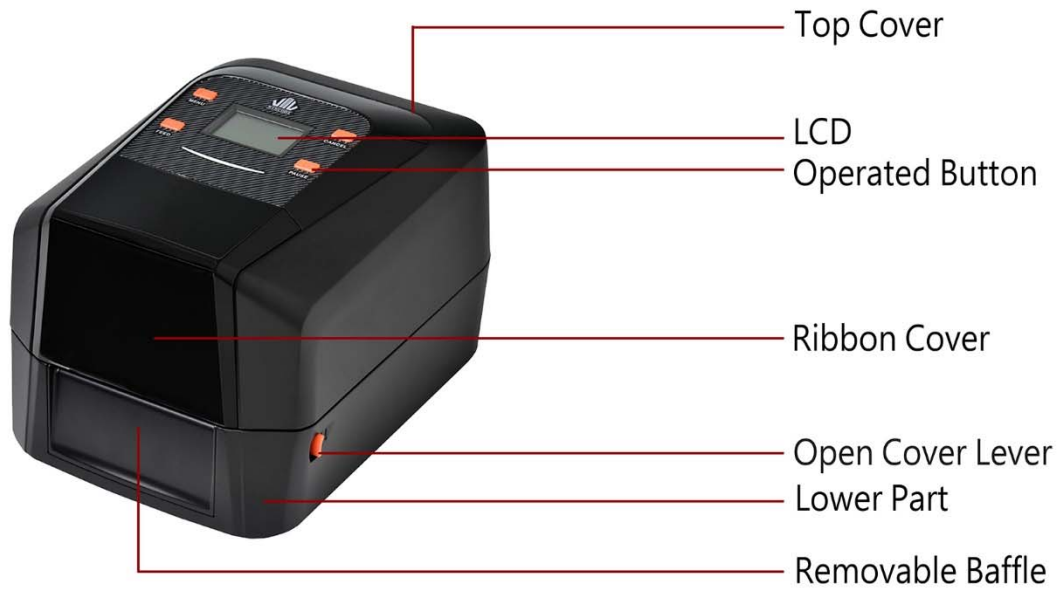

(Figure 1: Front View)

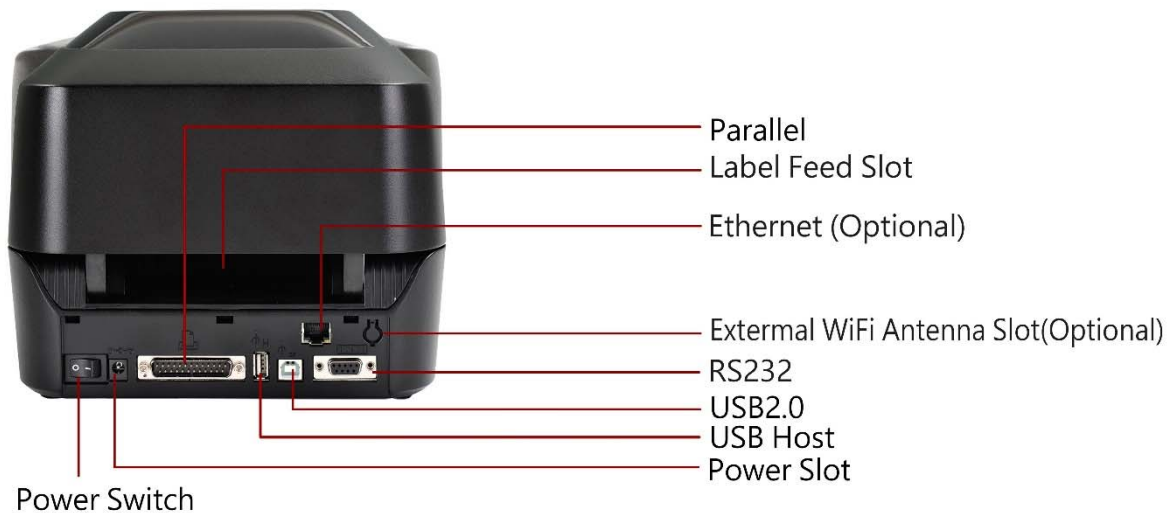

(Figure 2: Rear View)





3: Inside View)

## 2. Setup

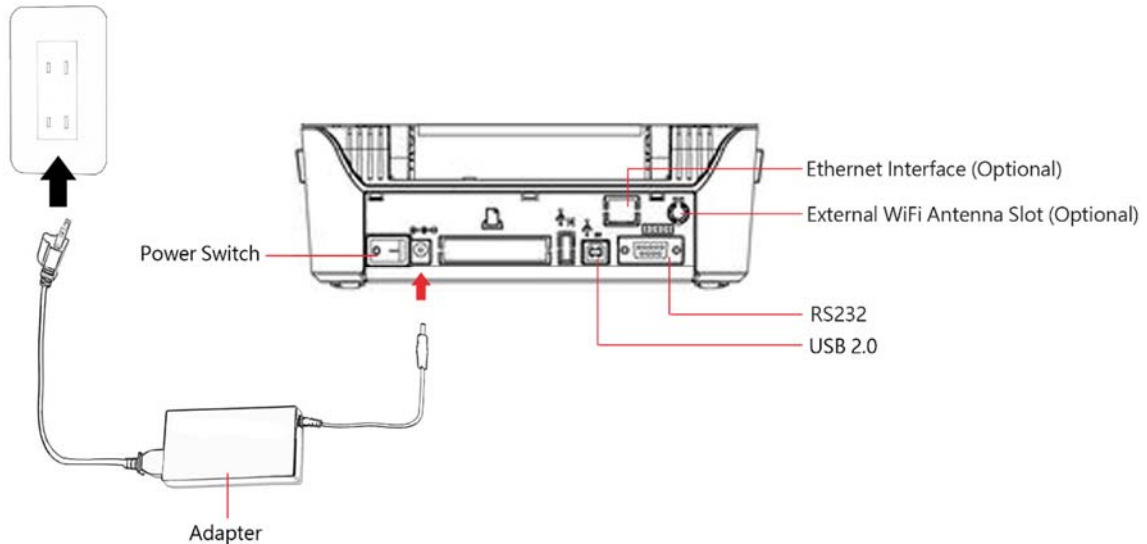

### 2.1 Setting up the printer



- 1) Place the printer on the flat surface.
- 2) Make sure the power switch is OFF.
- 3) Choose corresponding cable (RS232 or USB 2.0) to connect printer with computer.
- 4) Plug the DC power cord into the power slot and plug the AC power cord into a socket on the wall.

#### Note: Power Cord instruction

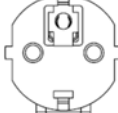
- To use 100-125 Voltage, please choose minimum rating power cord. (125V, 10A)
- To use 200-240 Voltage, please choose minimum rating power cord. (250V, 10-16A)
- Please select the power cord length less than 2 meter.
- Power cord is connected with adapter and have to plug in the jack  as ICE-320-C13 as right figure.

Country/ Area	North America/Taiwan	Europe	China
Power cord Voltage and Electricity Spec.	125V, 10A SVT 18AWG	250V,10A H05VV-F	250V,10A RVV H05VV-F
Plug (Refers to the local plug standard)	 125V, 10A	 250V, 16A	 250V, 10A

## 2.2 Ribbon Loading

- 1) 1" core (300m length ribbon)

Open the ribbon cover and top cover; Install an empty paper core onto the ribbon take-up spindle; Install a ribbon onto the ribbon supply spindle.



0.5" core (100m length ribbon)

Open the ribbon cover and top cover; install the two 0.5" ribbon caps on the right white holders.



- 2) Pull back the pressing lever, then load the right side of ribbon first into the ribbon supply mechanism.

The left side of ribbon supply spindle needs to be connected with bulge part of left supply mechanism completely (Turn the gear until the bulge part in the notch of spindle).



- 3) Load the right side of paper core first into the ribbon take-up mechanism.  
The left side of ribbon take-up spindle needs to be connected with bulge part of take-up mechanism completely. (Turn the gear until the bulge part in the notch of spindle).



- 4) Pull the ribbon to bypass print head and then attach the ribbon leader on the empty paper core with tapes, then rotate the ribbon rewind wheel until ribbon surface has no wrinkle; Close the ribbon cover to finish ribbon installation.





## 6. Ribbon Installation Path

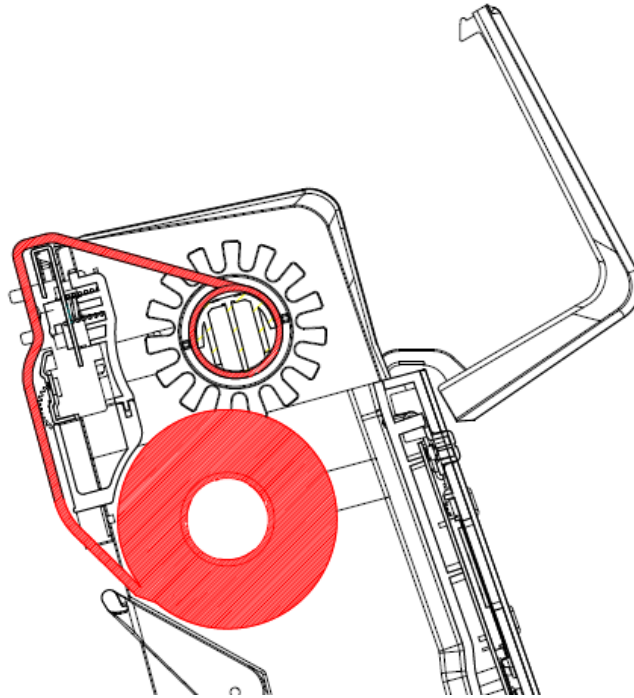



## 2.3 Label Loading

- 1) Hold on each side of label holder, press the orange buttons and then arrange the width, and place a label roll between the holders.



- 2) Pull the label paper through the rubber roller and push the both sides of label under the label guides. Close the top cover to finish label installation.



### 3) Label installation path

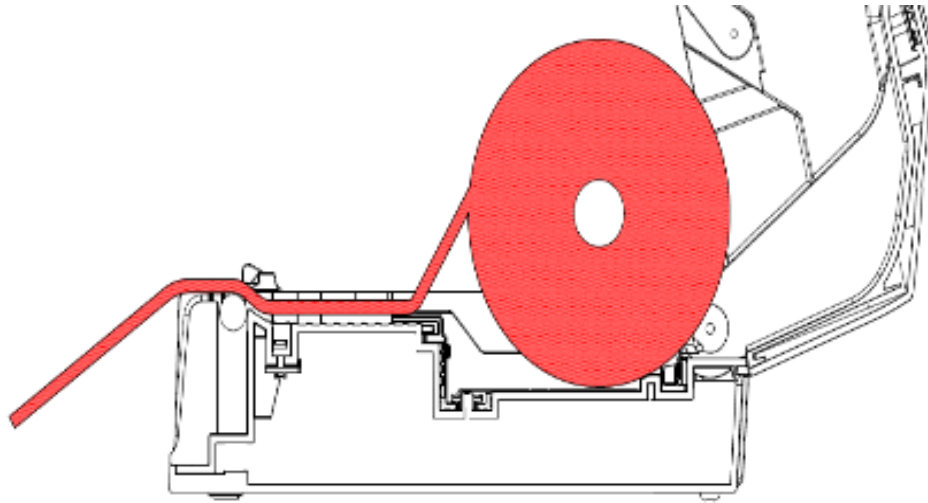

## 2.4 Real Time Clock Battery Installation

### 2.4.1 Get started (Battery is excluded in the LP4N model)

- 1) Turn off the power, and then remove the power cord and relevant connected cable.
- 2) Open the chassis cover at the bottom, there is a battery with insulation sheet.



- 3) Pull out the insulation shim.

### 2.4.2 Replace the battery

- 1) Turn off the power and disconnect all the cables attached.
- 2) Loose the three screws at the bottom, and then open the lower part cover to see the motherboard.
- 3) Press the button beside the battery as below figure.
- 4) The battery would be left from the mount.
- 5) Place a new battery and then press until it is fixed in the installation mount.

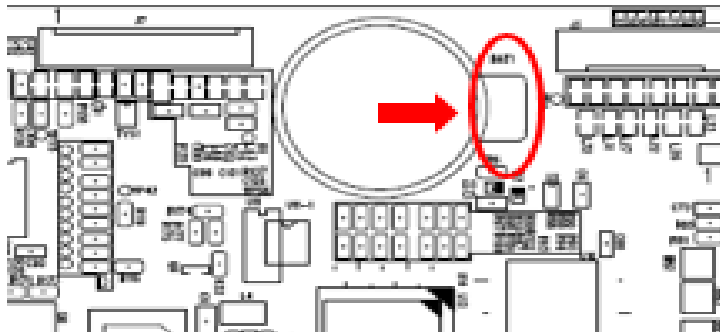

\*Notice: the battery model CR2032 is recommended.

## 2.5 Cutter Installation (Optional)

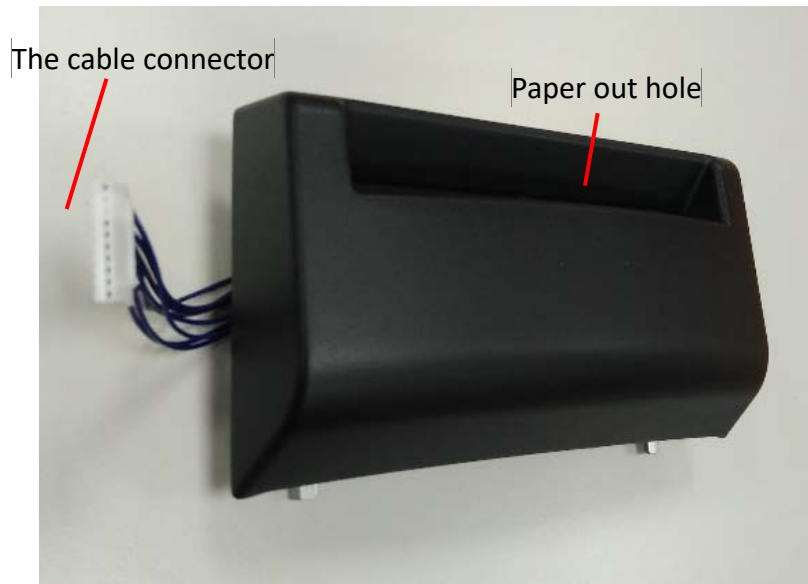

- 1) Turn off the power and disconnect all the cables attached.
- 2) Open the upper cover and take down the front baffle.
- 3) Make the connected cable go through the hole of right side of lower part.

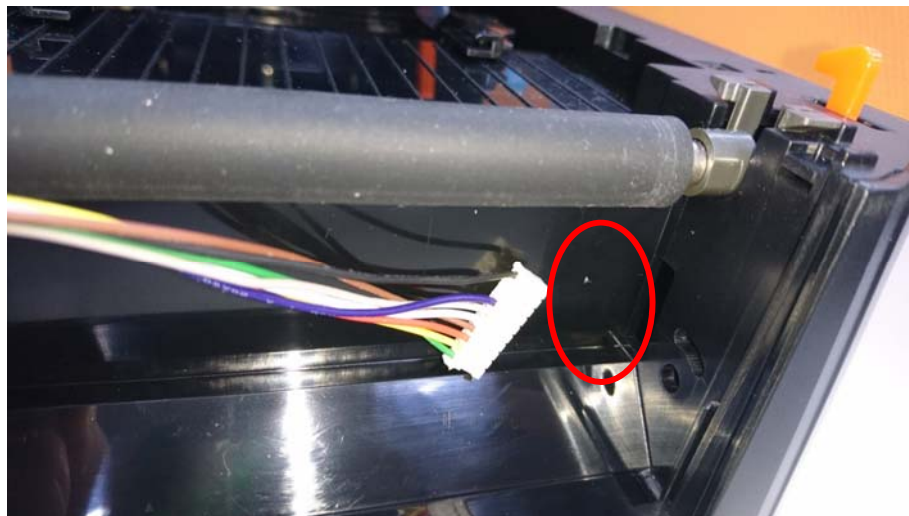

- 4) Place the cutter in the position of the front baffle, and then close the cover.

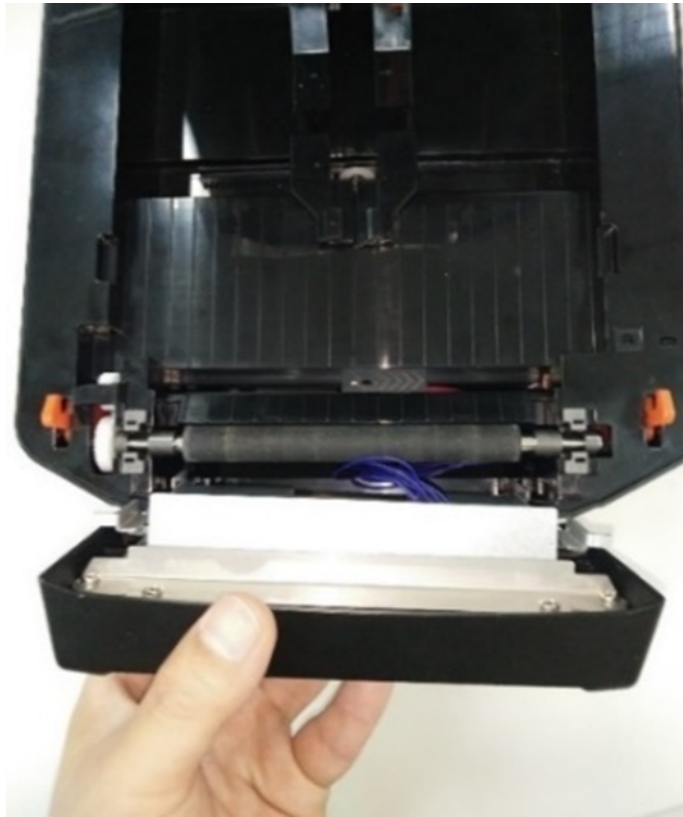

- 5) Open the bottom cover, and find the cable of cutter inside.



- 6) Place this cable into the slot of motherboard, and close the bottom cover.



### 2.5.1 Label Installation

- 1) Follow [2.3](#) to load on the label.
- 2) Pull out the label through the paper outlet hole, and then close the cover.





## 2.6 Peeler Installation (Optional)

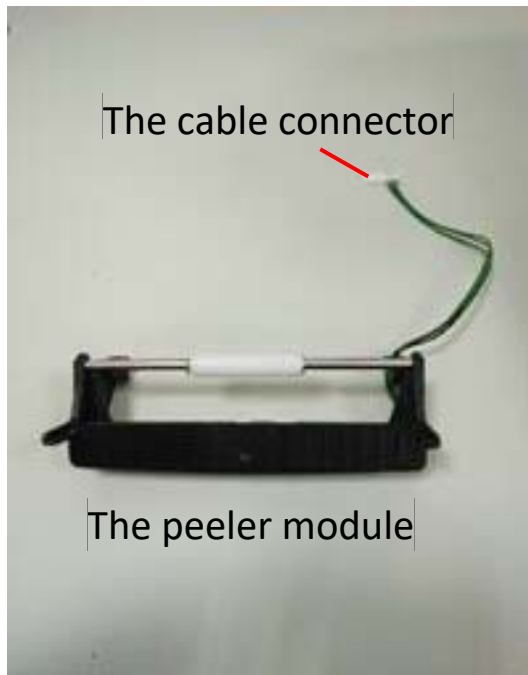

- 1) Turn off the power and disconnect all the cables attached.
- 2) Open the upper cover and take down the front baffle.
- 3) Make the connected cable go through the hole of right side of lower part.





- 4) Install the peeler module into the two holes of the left and the right sides of the lower cover part (right-side go first).



- 5) Place the spring part on the iron piece firstly, and install this iron piece into the notches (spring side in the right side) and then check if the arrow mark of iron piece pointing to the front.



- 6) Open the peeler module, and then close the upper cover.
- 7) Open the bottom cover and find the peeler cable connector.
- 8) Place the cable connector into the slot of motherboard and then close the bottom cover.



## 2.6.1 Label Installation

- 1) Follow [2.3](#) to load on the label.
- 2) Tear the first labels and leave the backing liner, pull down the backing liner and make the label through between the iron piece and white roller.



- 3) Push back the peeler module, and then close the upper cover.



### 3. Driver installation

The printer could support USB, RS232 and TCP/IP connection. After WinLabel installation, the user could find and execute it in the start menu of Windows.

For the WIFI or Ethernet connection, please select "adding TCP/IP port" to install driver.

For RS232 connection, please select COM port to install driver.

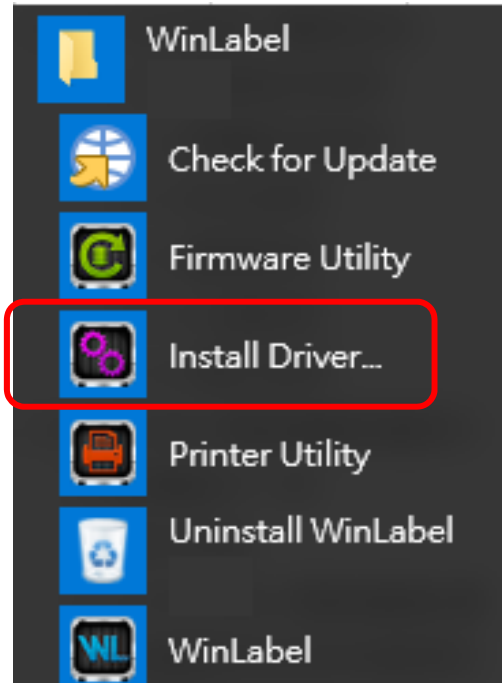

### 3.1 Printer Installation

#### Step1

After WinLabel installation, the user could find the "Install Driver" icon in the START menu to execute it.

Connect printer to the computer with USB/ RS-232 / LPT cable and then press the Next icon.



#### Step2

Choose the model of the printer and then click "Next".

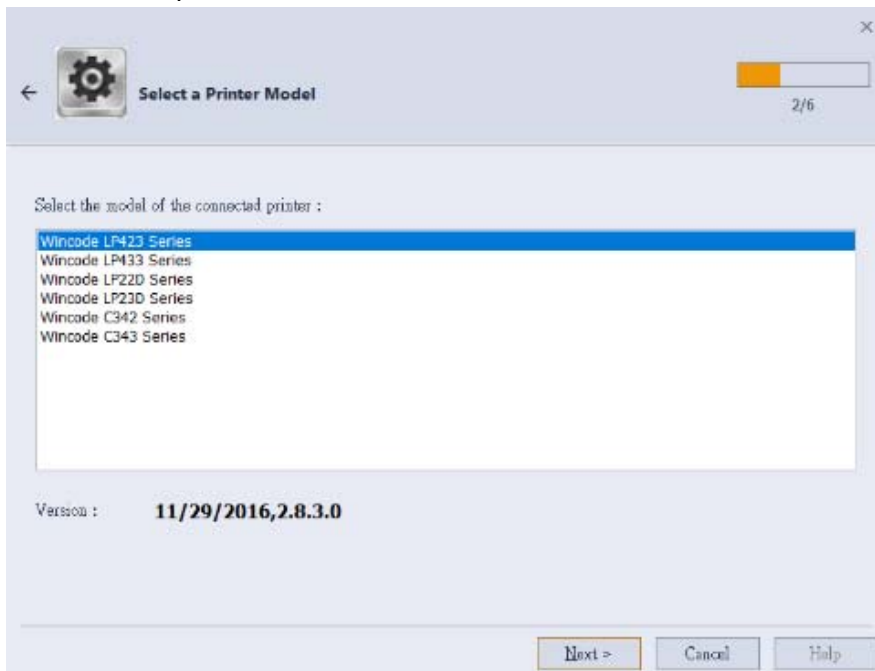

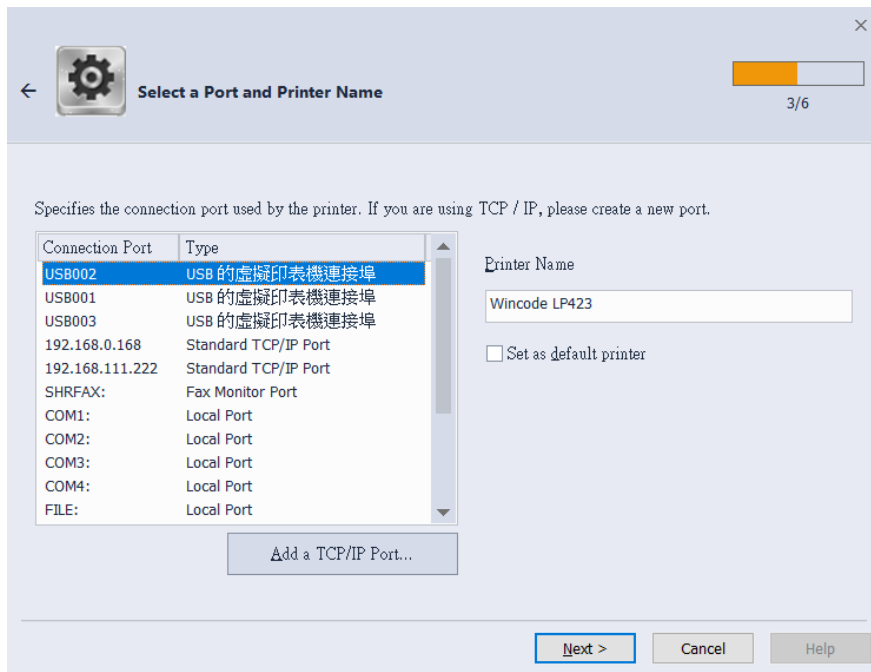

- USB connection: the program will select the connected port automatically.
- RS-232, LPT connection: please select the corresponding COM or LPT port.
- Ethernet or WIFI or share IP connection: please select “add a TCP/IP port”
  - Automatically search: this function would search the whole printers that are ready connected to the router, it will bring a corresponding IP of each printer automatically.
  - If the user selects the manual IP input, please insert the custom IP and port (default: 9100).

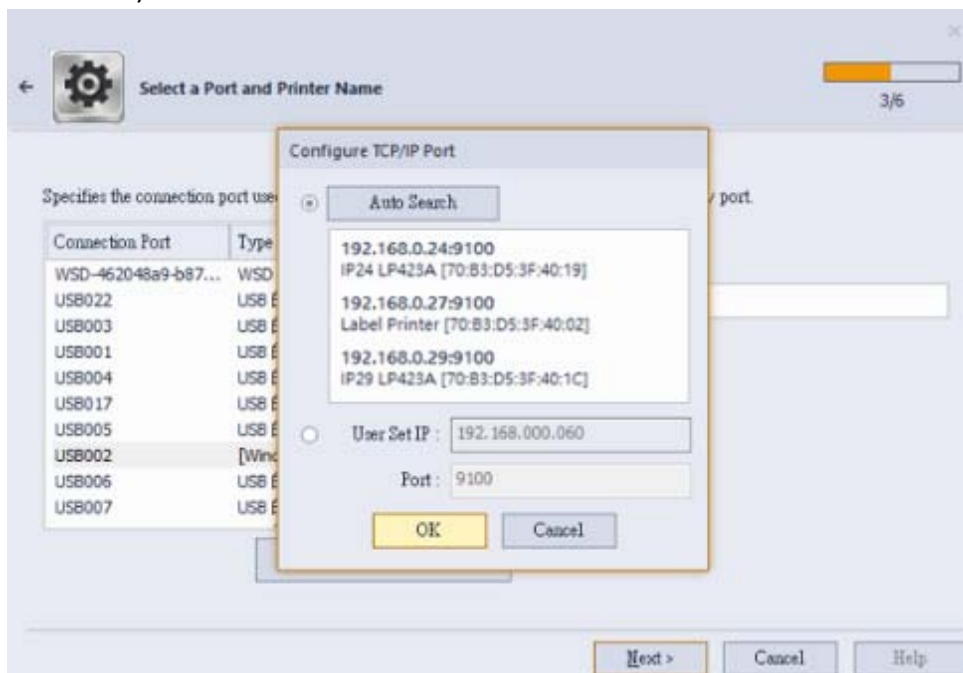

### Step3

If the showed information is correct, click “Next” to start driver installation.

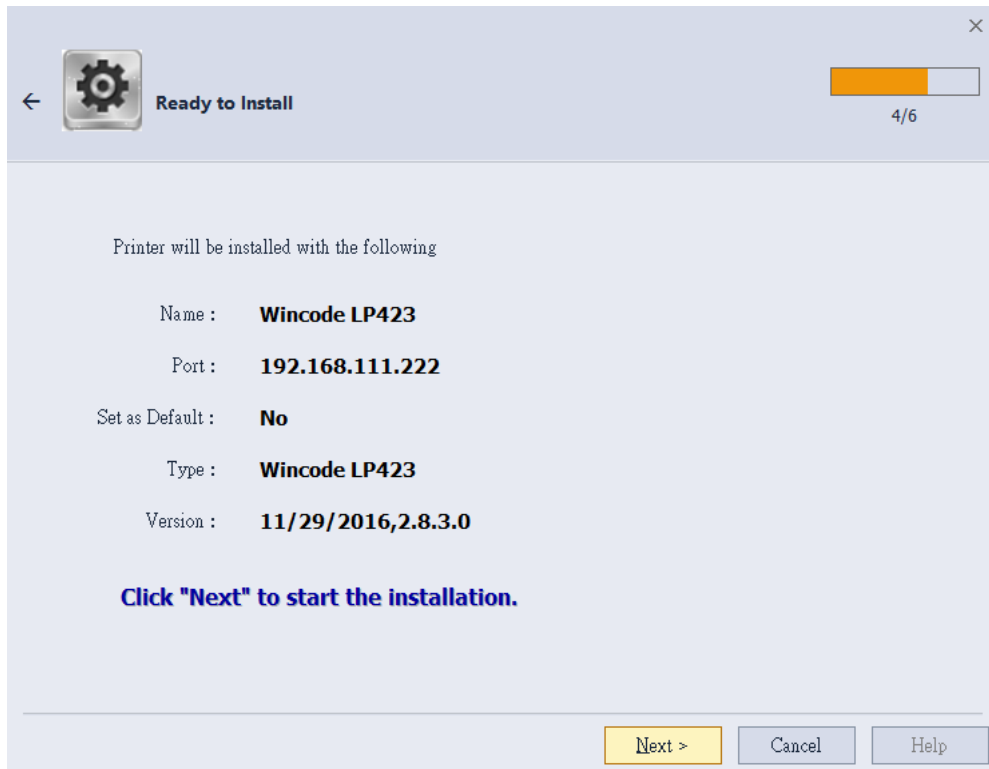

### Step4

The driver installation would require several minutes.

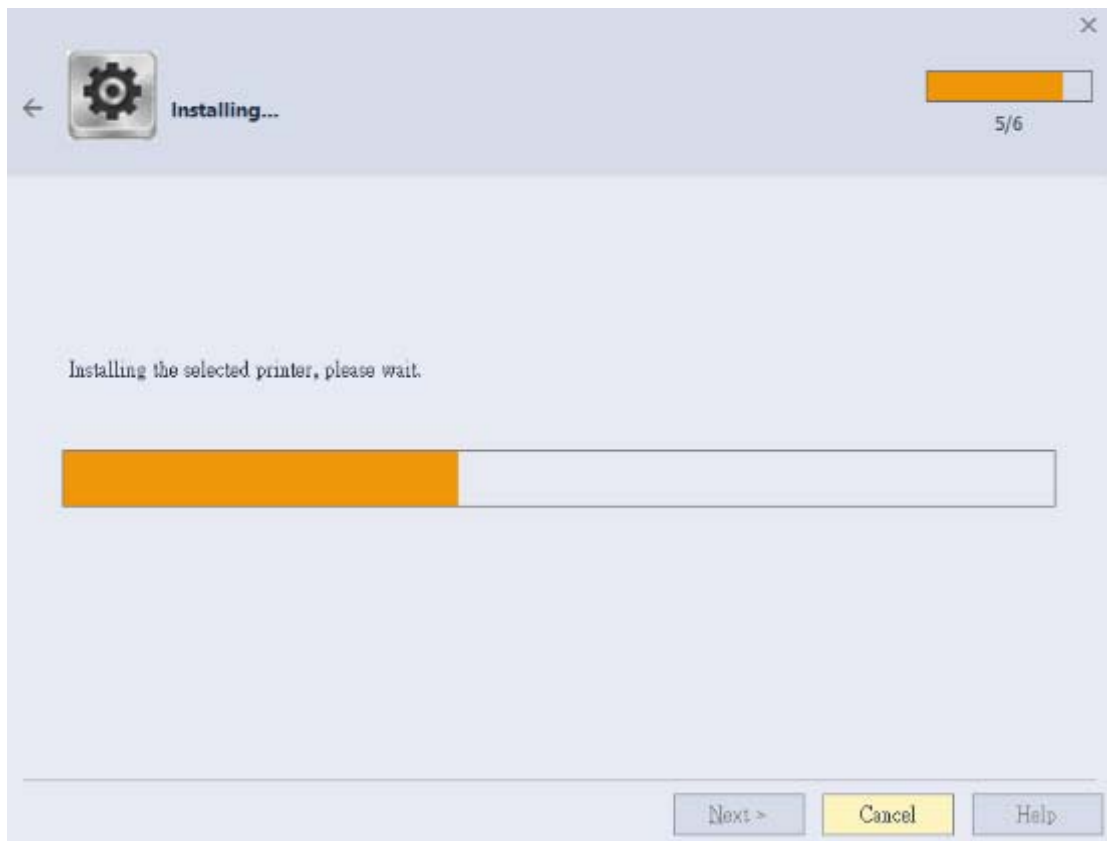

**Step5**

If a “Windows Security” window popup, please select “install this driver software anyway”.

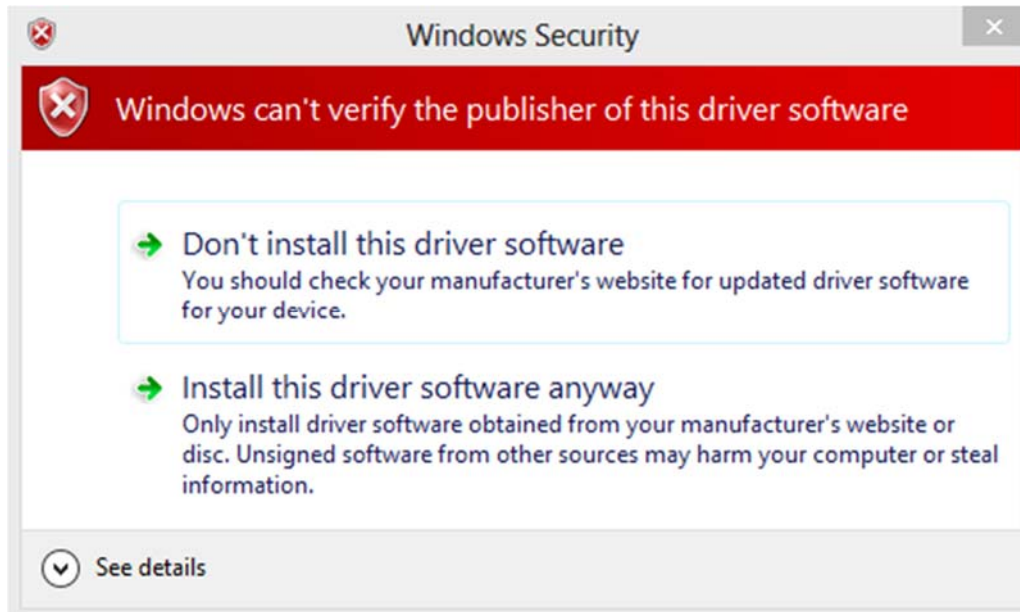
**Step6**

The driver installation is finished.

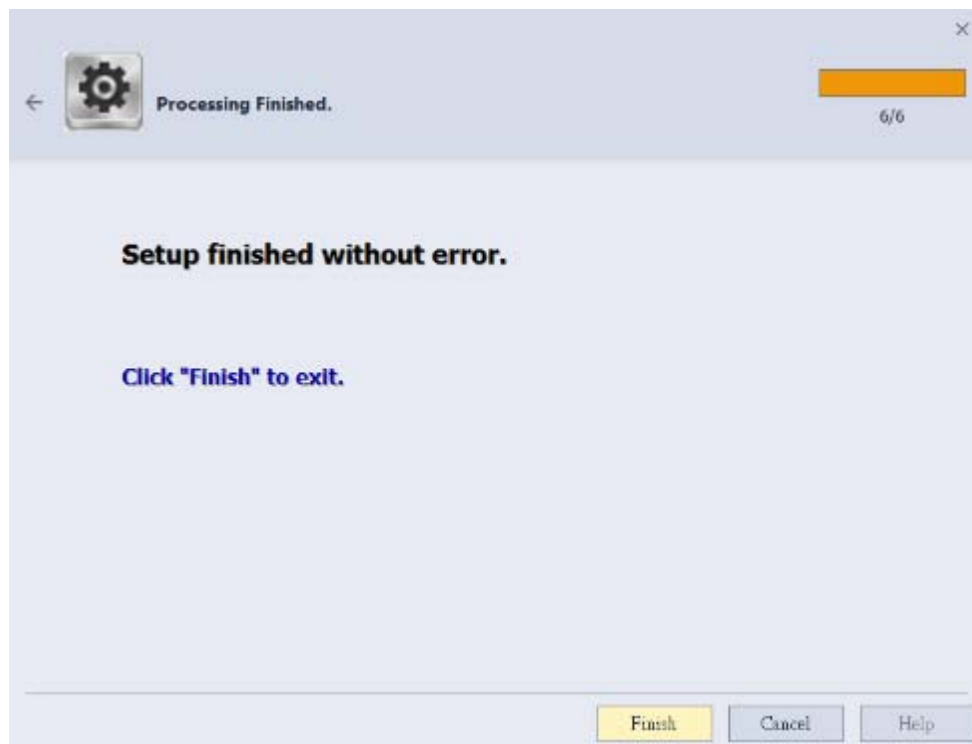



### 3.2 Install driver with “Add a Printer” in Microsoft

Use the “add new printer” at the control panel of Microsoft to install the driver

- Windows 10 Platform
  - 1) Click “Start” > “Setting” > “Devices”> “Printers & scanners”
  - 2) Click “Add a printer or scanner” and then start searching, if the device cannot be found, select “The printer that I want isn’t listed”

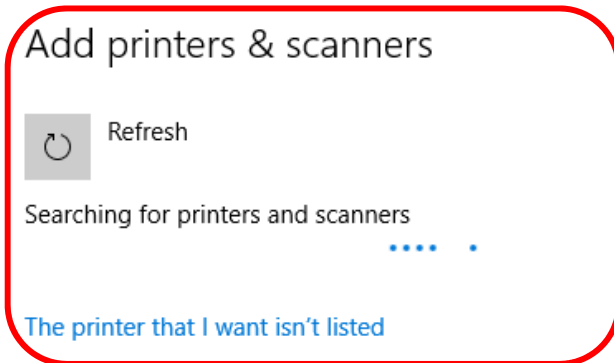

#### Printers & scanners

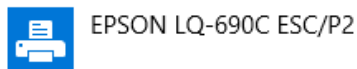

- Windows 7 and Windows 8 Platform
  - 1) Enter “Devices and printers” from the control panel or click “start” and select “Devices and printers”
  - 2) Click “Add a new printer”

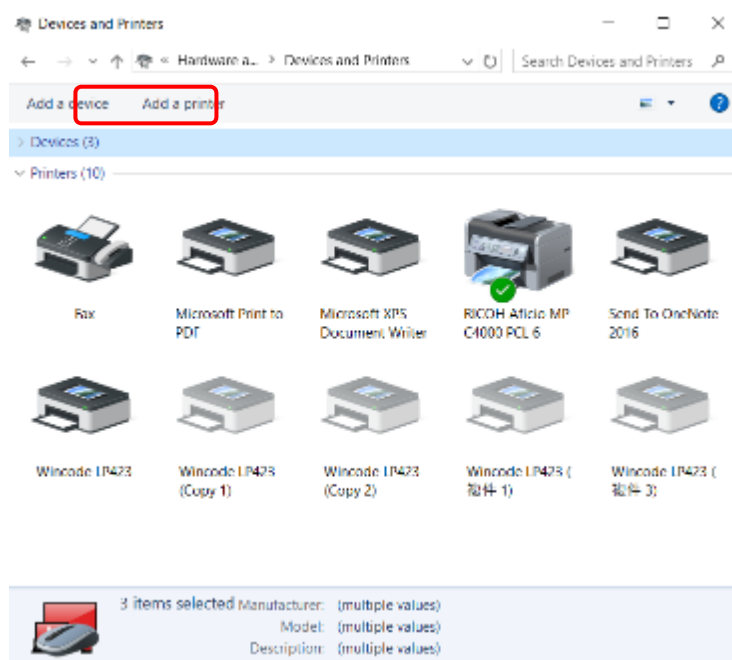

- Windows XP Platform
  - 1) Enter “Printers and Faxes” from the control panel or click “start” and select “Setting” > “Printers and Faxes”
  - 2) Click “Add a printer” > “Add a printer wizard”

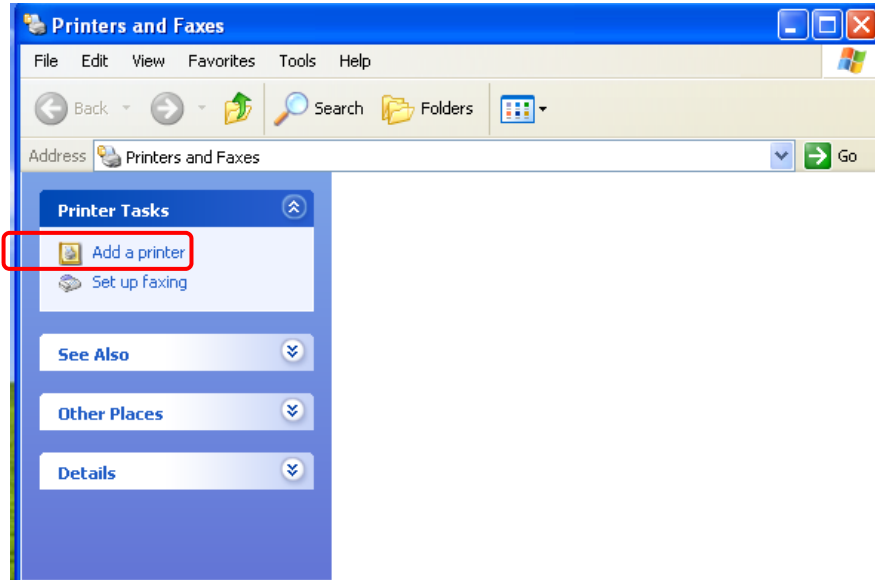

### 3.2.1 Printer Installation

(For example: in the windows 10 platform)

- 1) Follow the step above, select “The printer that I want isn’t listed” > “Add a local printer or network printer with manual settings” > “Next”

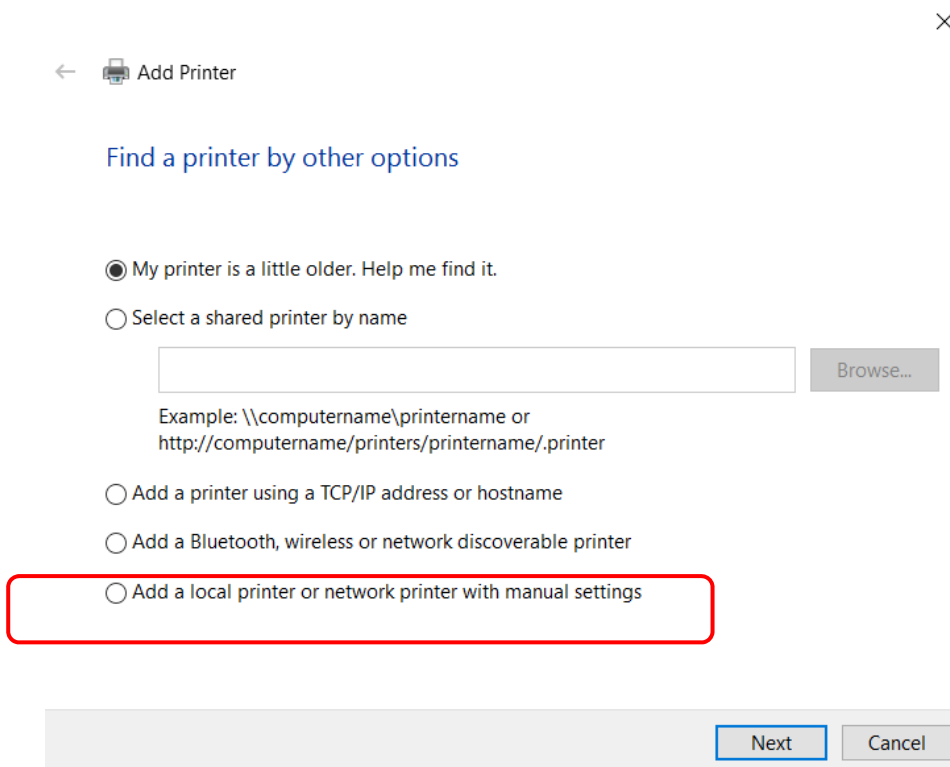

## 2) Choose a printer port

- For USB, COM, LPT printers, please select “Use an existing port”, choose the corresponding port, then click “Next” (Then go to step “6”)

×

←  Add Printer

### Choose a printer port

A printer port is a type of connection that allows your computer to exchange information with a printer.

Use an existing port: LPT1: (Printer Port) ▾

Create a new port:

Type of port: Local Port ▾

Next Cancel

- For TCP/IP printers, please select “Create a new port”, choose the type of connected port, click “Next”

×

←  Add Printer

### Choose a printer port

A printer port is a type of connection that allows your computer to exchange information with a printer.

Use an existing port: LPT1: (Printer Port) ▾

Create a new port:

Type of port: Local Port ▾  
Local Port  
Standard TCP/IP Port

Next Cancel

3) Key-in the IP address of the printer and then click “Next”.



←  Add Printer

### Type a printer hostname or IP address

Device type:	TCP/IP Device
Hostname or IP address:	192.168.0.123
Port name:	192.168.0.123
<input checked="" type="checkbox"/> Query the printer and automatically select the driver to use	

Next

Cancel

4) Wait for TCP/IP port detecting.



←  Add Printer

### Detecting TCP/IP port

Detecting the TCP/IP port..  
Windows will automatically move to the next page when the detection is complete.



Next

Cancel

- 5) Select “Custom” in “Settings”, and fill up the port name, printer name or IP address. For Protocol, please select “Raw”. For Port Number, please fill up “9100”. Select “OK” > “Next”.

←  Add Printer

### Additional port information required

The device is not found on the network. Make sure that:

1. The device is turned on.
2. The network is connected.
3. The device is properly configured.
4. The address on the previous page is correct.

If you think that the address is not correct, click Back to return to the previous page. Then correct the address and perform another search on the network. If you are sure that the address is correct, select the device type below.

Device Type

Standard Generic Network Card

Custom [Settings..](#)

[Next](#) [Cancel](#)

Configure Standard TCP/IP Port Monitor

Port Settings

Port Name: 192.168.0.123

Printer Name or IP Address: 192.168.0.123

Protocol

Raw  LPR

Raw Settings

Port Number: 9100

LPR Settings

Queue Name:

LPR Byte Counting Enabled

SNMP Status Enabled

Community Name: public

SNMP Device Index: 1

[OK](#) [Cancel](#)

- 6) Choose the printer driver that you want to install, and select the printer manufacturer and then select the printer driver . Click “Next”.

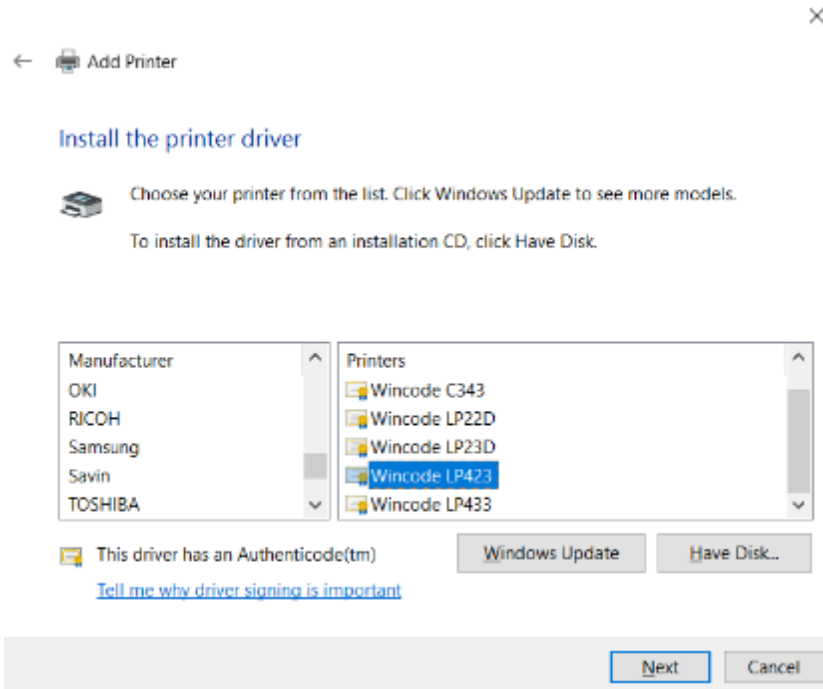

\*If the same driver has been installed, it will show the following window, select “Replace the current driver” and click “Next”.

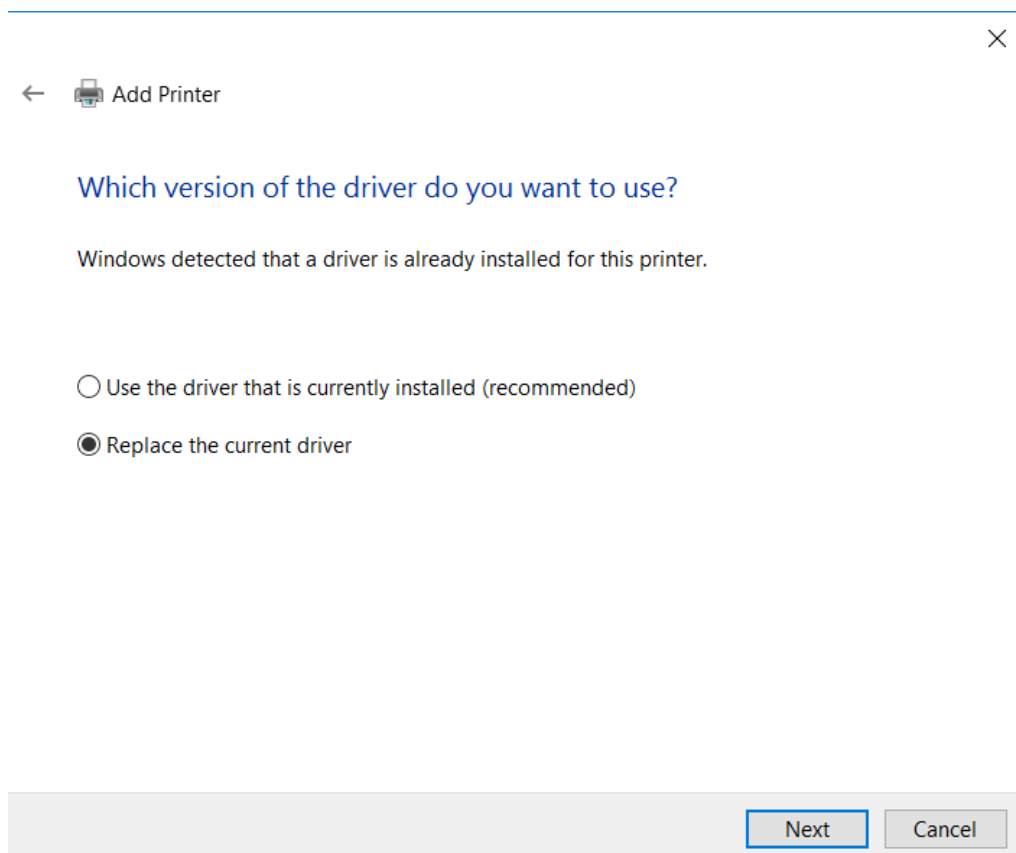

7) Enter the printer name, click “Next”.

×

←  Add Printer

### Type a printer name

Printer name:

This printer will be installed with the Wincode LP423 driver.

8) Select “Do not share this printer” click “Next”.

×

←  Add Printer

### Printer Sharing

If you want to share this printer, you must provide a share name. You can use the suggested name or type a new one. The share name will be visible to other network users.

Do not share this printer

Share this printer so that others on your network can find and use it

Share name:

Location:

Comment:

9) The user may select “Set as the default printer”, click “Finish”.



←  Add Printer

You've successfully added Wincode LP463

Set as the default printer

To check if your printer is working properly, or to see troubleshooting information for the printer, print a test page.

[Print a test page](#)

[Finish](#)

[Cancel](#)



## 3.3 Printing Setup (Driver Setup)

### 3.3.1 Page Setup

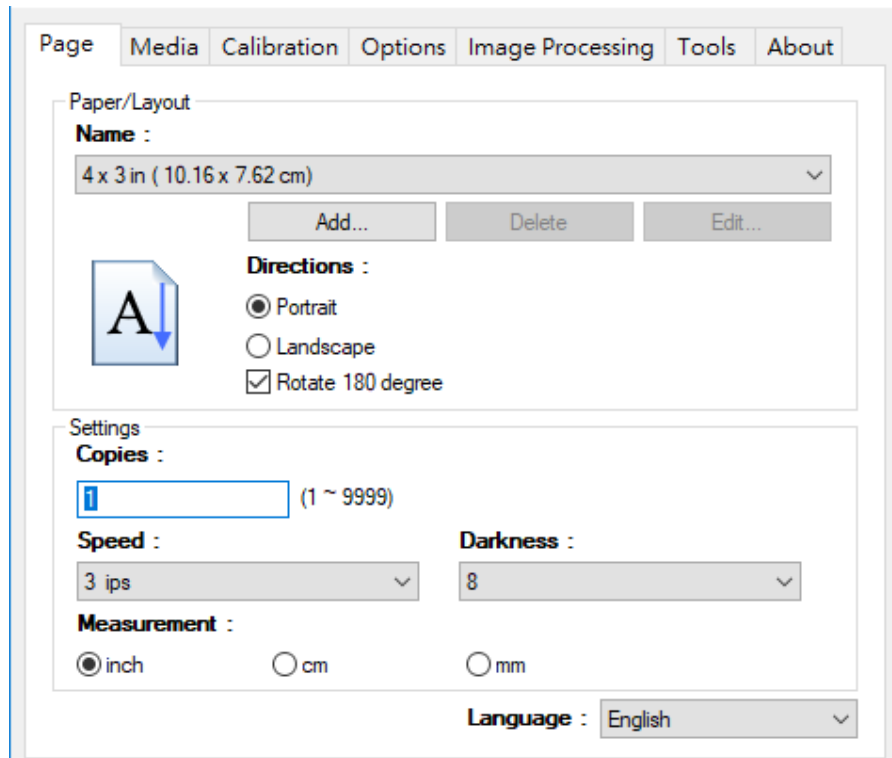

Item	Description
Paper/Layout	<ul style="list-style-type: none"> <li>➤ Name : Choose paper size (4 x 3 inch and 2 x 1 inch); User can also define frequently-used paper size by adding new label format.</li> <li>➤ Directions : Portrait and landscape (rotate 90 degrees); 180 degrees rotation is default settings.</li> </ul>
Settings	<ul style="list-style-type: none"> <li>➤ Copies : Each page quantity</li> <li>➤ Speed : Printing speed</li> <li>➤ Darkness : Adjust Printing darkness status.  <b>Caution:</b> If the value is higher, that would cause the temperature of print head higher, and would make ribbon melting and breaking easily. (Suggest value less than 8 for wax ribbon, the value more than 10 for resin ribbon)</li> <li>➤ Measurement : inch, cm, and mm.</li> </ul>

### 3.3.2 Media Settings

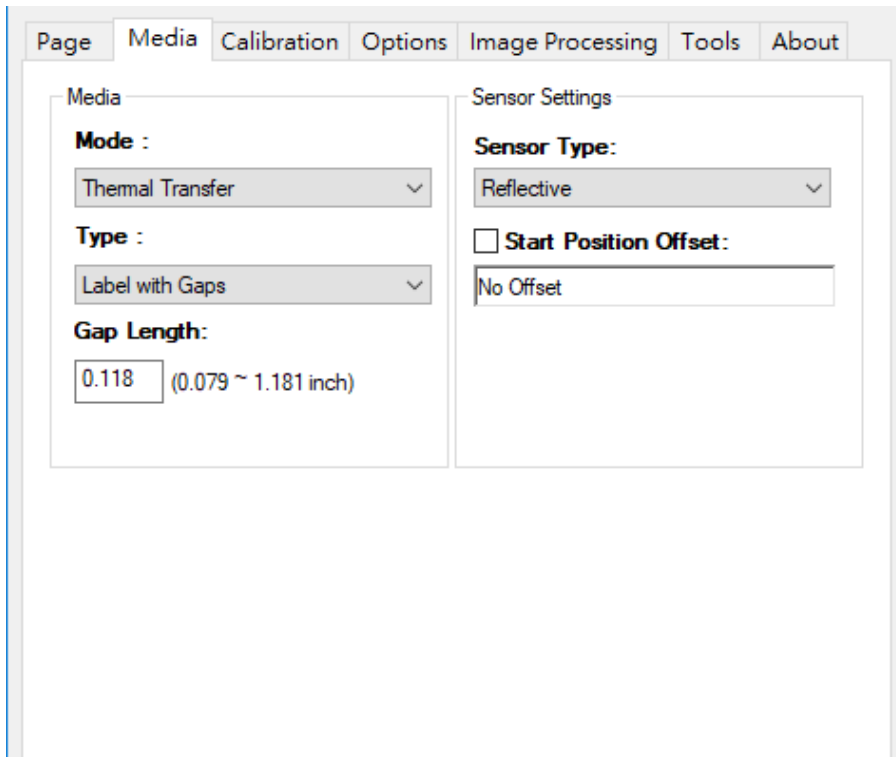

Item	Description
Media settings	<p>Mode: Thermal Transfer and Direct Thermal.</p> <p>“Thermal Transfer” mode means that printer needs to be loaded ribbon for printing.</p> <p>“Direct Thermal” mode means that printer does not require ribbon but need to be loaded thermal paper.</p>
Media type	<p>Label with gaps :</p> <ul style="list-style-type: none"> <li>➤ “Gap Length” is the distance between two labels.</li> </ul> <p>Label with marks :</p> <ul style="list-style-type: none"> <li>➤ “Black Line” is the thickness in each black line.</li> </ul> <p>Continuous :</p> <ul style="list-style-type: none"> <li>➤ Continuous label type: Ignoring the gap or mark of label</li> <li>➤ Stop On Last Element: Printing action will stop while printing the last label</li> </ul>
Sensor settings	<p>Sensor type:</p> <ul style="list-style-type: none"> <li>➤ Use Current Printer Setting (by previous setting)</li> <li>➤ Reflective sensor (<b>Recommend</b>)</li> </ul>

➤ Transmissive sensor

Start Position Offset: (recommend to input number when the printing pattern has a little bit shift up or shift down)

If selected, user could fill up the value by dot.

(+value: pattern shifts up; 203dpi: 1mm=8 dots; 300dpi: 1mm=12 dots.)

### 3.3.3 Sensor Calibration

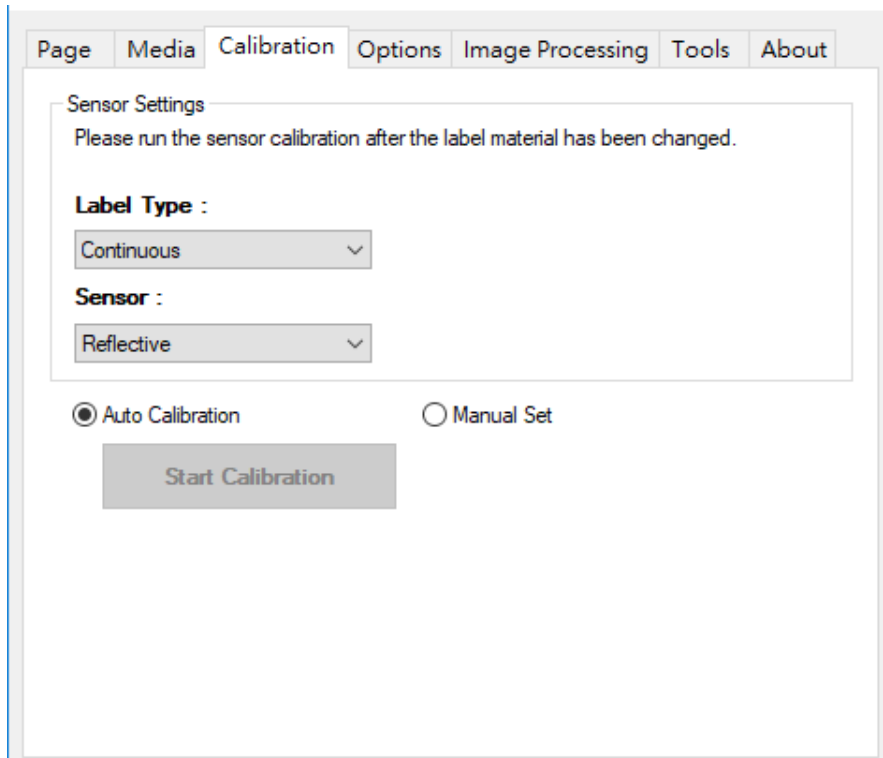

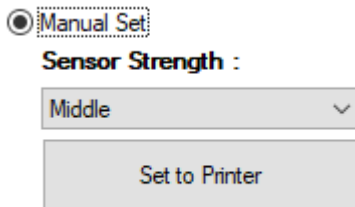
Item	Description
Auto Calibration	<p>The calibration would adjust the sensitivity of sensor according to the feeding label thickness.</p> <p>We suggest to run the “Auto calibration” for most kinds of labels, or while the label material is different from the previous label. If it is the same material but different size, user only needs to adjust the page size.</p>
Manual Set	<p>➤ Sensor Strength: Middle or High are recommended. Higher sensor strength would detect thicker label.</p> 

### 3.3.4 Options

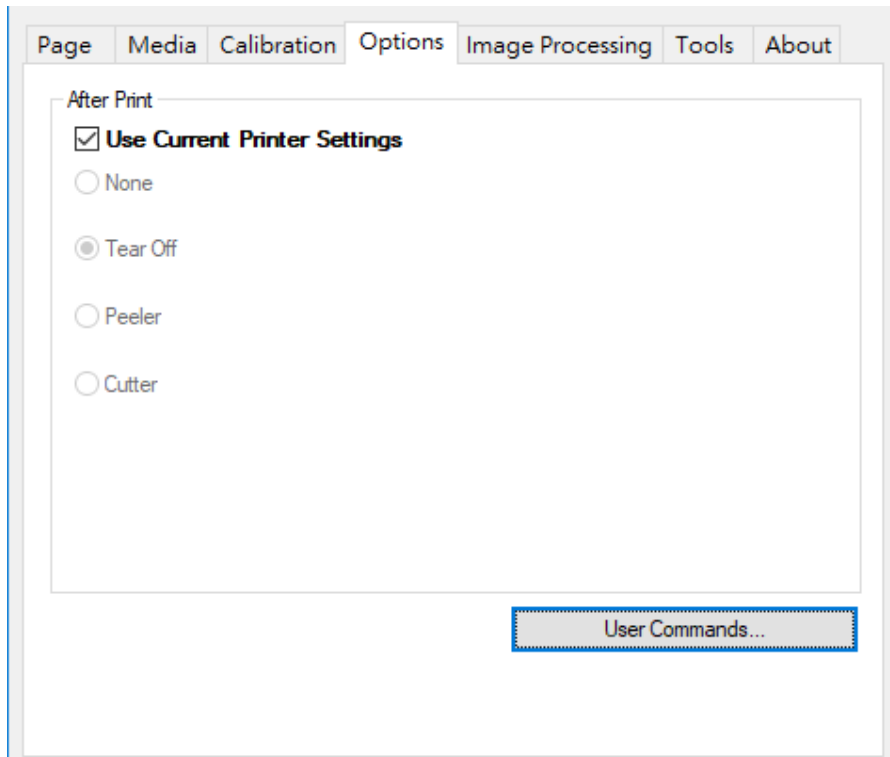

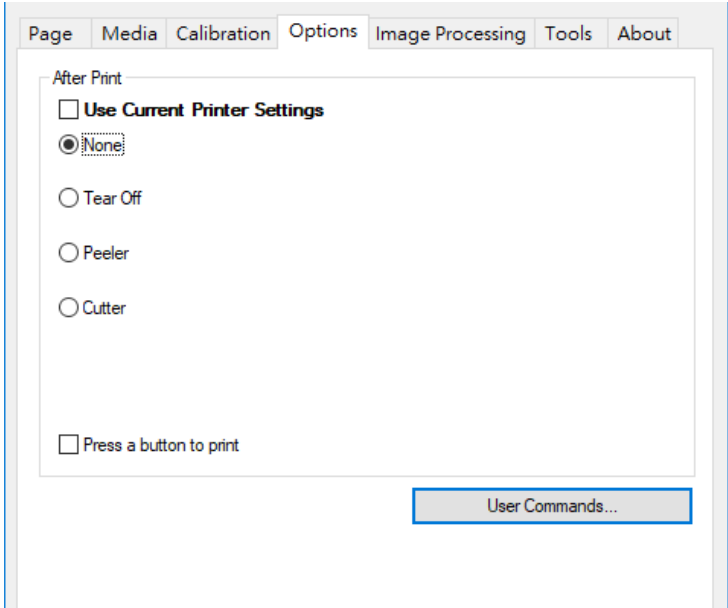
Item	Description
After Print	<p data-bbox="491 1131 1260 1198">Default: Use Current Printer Settings. The below options will show after removing the tick.</p> <ul style="list-style-type: none"> <li data-bbox="491 1220 1260 1288">➤ None: The label will be stopped after printing the last label.</li> </ul> <div data-bbox="526 1294 1257 1899" style="border: 1px solid gray; padding: 5px; margin: 10px 0;">  </div> <ul style="list-style-type: none"> <li data-bbox="491 1937 1260 2004">➤ Tear off: The label gap will be stopped at the tear off position that letting user easily tear off the label.</li> </ul>

The tear off position is adjustable as long as selecting the “Tear Off Position” option.

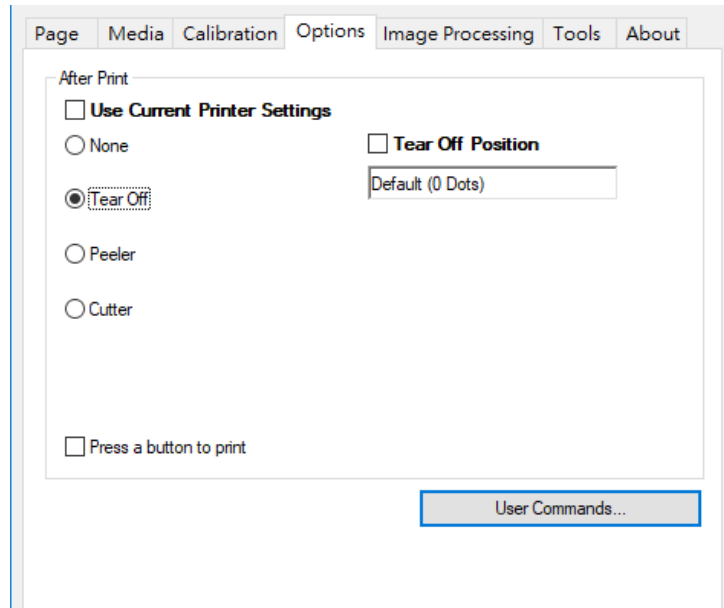

- Peeler: with peeler module, the labels can be peeled continuously while printing. The printer will feed the next label after the current label peeled.

The Peel position can be adjusted with the “Peel Off Position” selected.

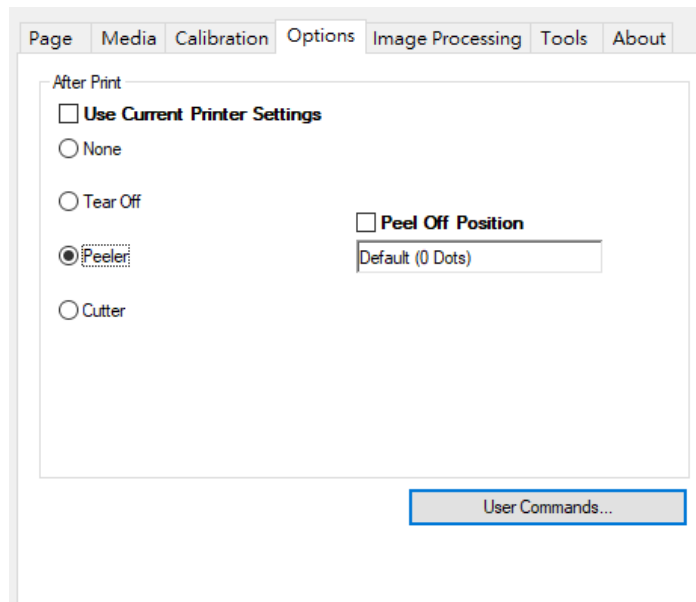

- Cutter: with cutter module, the cutter operates after printing each label.

“Every Cut”: the amount of pages that come out once running the cutter.

“Cut Position”: the cutting position will be adjustable while selected.

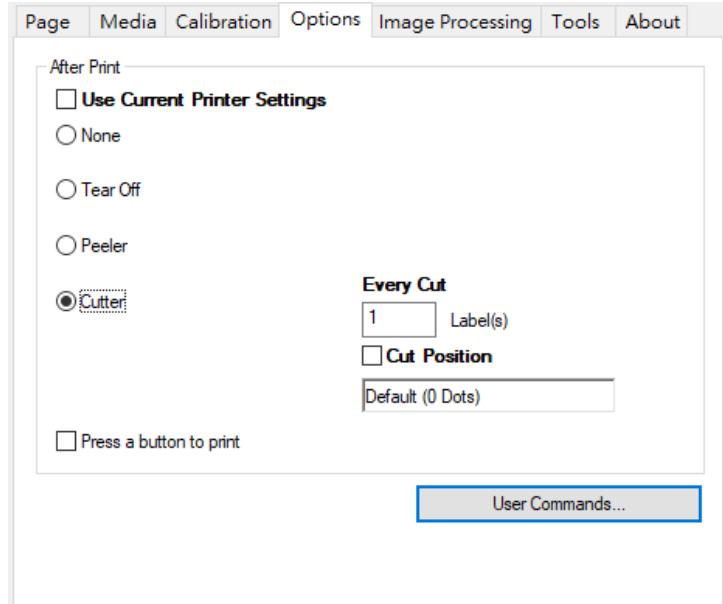

User Commands

User can fill in the printer commands in this dialog when it is needed. Select and press “...”, a new window will pop out and the user can key in the commands.

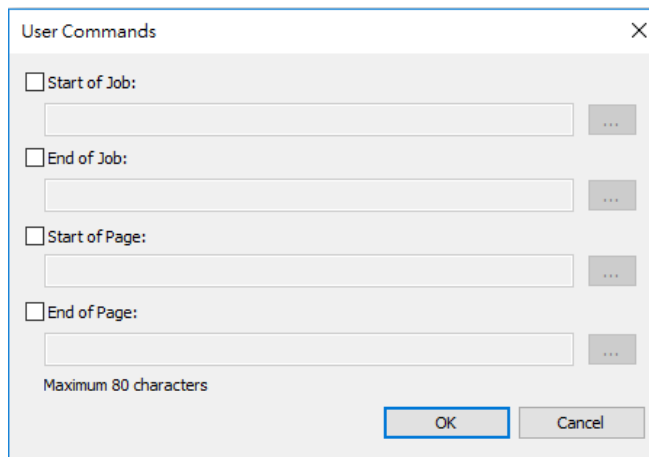

### 3.3.5 Image Processing

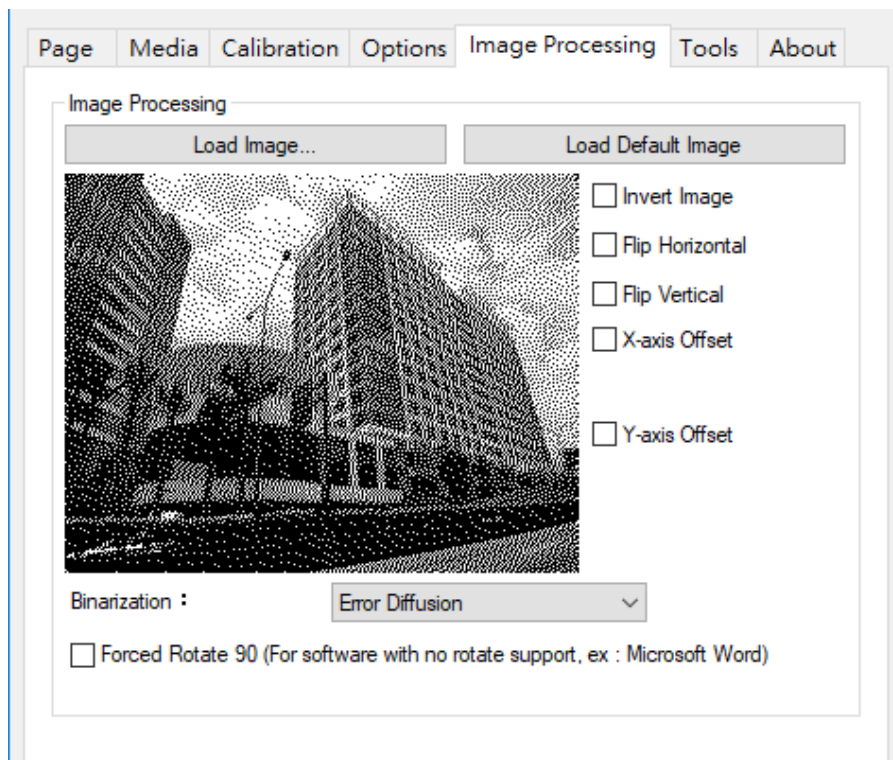

Item	Description
Image Processing	<ul style="list-style-type: none"> <li>➤ Load Image: The selected image will be displayed in below area.</li> <li>➤ Load Default Image.</li> <li>➤ Binarization:           <p>Converts color images to different kind of black-and-white image.</p> <div data-bbox="810 1317 1040 1505" style="border: 1px solid black; padding: 2px;"> <p>F&amp;S Error Diffusion ▼</p> <p>F&amp;S Error Diffusion</p> <p>Bayer 4 x 4</p> <p>Bayer 8 x 8</p> <p>Cluster 6 x 6</p> <p>Cluster 8 x 8</p> <p>Cluster 16 x 16</p> <p>Bayer 16 x 16</p> <p>Threshold</p> </div> </li> <li>➤ Invert Image: Convert image color.</li> <li>➤ Flip Horizontal: Flip along X axis.</li> <li>➤ Flip Vertical: Flip along Y axis.</li> <li>➤ X-axis Offset: Adjust the print position in the horizontal direction.</li> <li>➤ Y-axis Offset: Adjust the print position in the vertical direction.</li> <li>➤ Forced Rotate 90° (If the software with no rotation support. e.g. Microsoft Word.): Only select when there is the printing rotation error in landscape direction.</li> </ul>



### 3.3.6 Tools

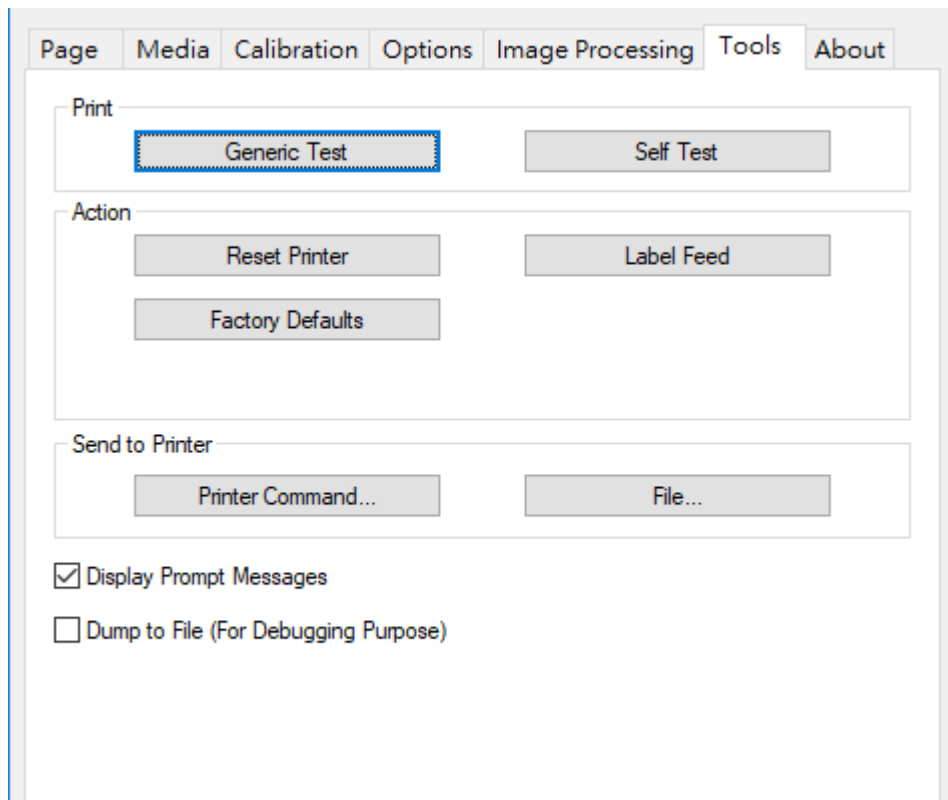

Item	Description
Print	<ul style="list-style-type: none"> <li>➤ Generic Test: ask printer to print a label with texts for testing purpose.</li> <li>➤ Self-Test: ask printer to print a label with inside parameters of printer.</li> </ul>
Action	<ul style="list-style-type: none"> <li>➤ Reset Printer : Restart printer.</li> <li>➤ Factory Defaults : Inside parameters to be default</li> <li>➤ Label Feed : ask printer to deliver a label come out</li> </ul>
Send to Printer	<ul style="list-style-type: none"> <li>➤ Printer Command: Send commands to the printer, please refer to the <u>WINCODE's WPL Command Manual</u>.</li> <li>➤ Files : Select a command file (*.prn) from the stored space of computer</li> </ul>
Dump to File (For Debugging Purpose)	<ul style="list-style-type: none"> <li>➤ Click this option to generate .prn file when use the third-party software.</li> </ul>

### 3.3.7 About

WINCODE driver version.

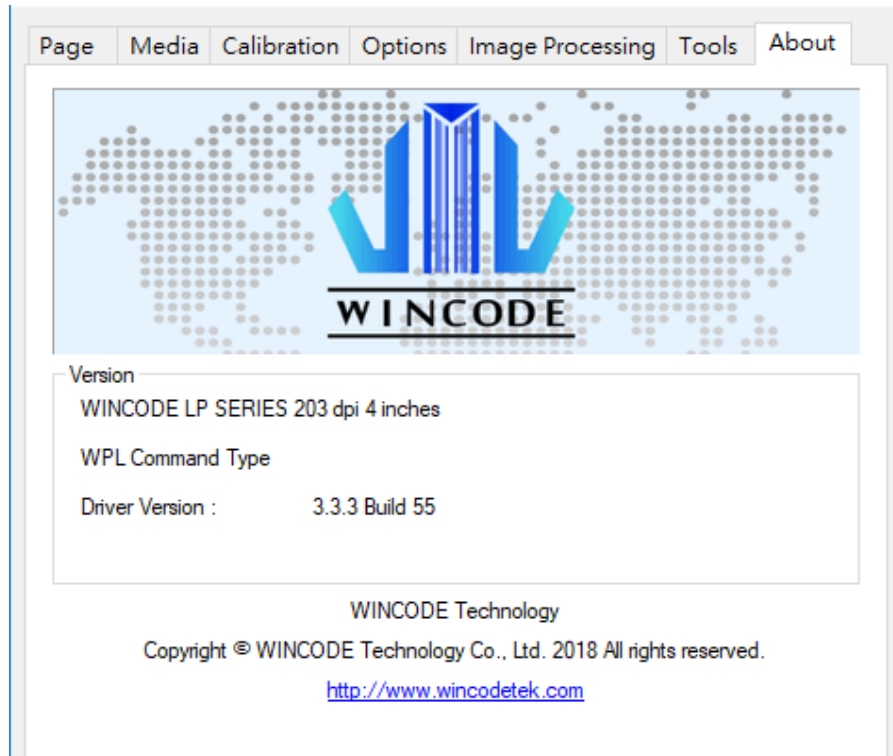







## 4. WinLabel tool suite

### 4.1 Software Introduction

WinLabel tool suit supports the below platform: Windows Vista, Windows 7, Windows 8, Windows 8.1, Windows 10, Server 2003, Server 2008, Server 2012 and Server 2012R2 operation system (32 bit and 64 bit).

**Note:** The monitor resolution needs to be at least 1024 x 768 for normal use.

Icons	Description
	WinLabel : Label editing software
	Printer Utility : Printer tool
	Install Driver : Driver installation tool
	Firmware Driver : Firmware update tool
	Check for Update : Version check
	Uninstall WinLabel : Uninstall all installed software

## 4.2 Software Installation

Click “WINLABEL\_SETUP.EXE” file which could be downloaded from our official website (<http://www.wincodetek.com/service>), choose a preferred language (English, Spanish, Turkish, traditional Chinese, simplified Chinese, and Korean) and then input a stored path to finish the software installation.

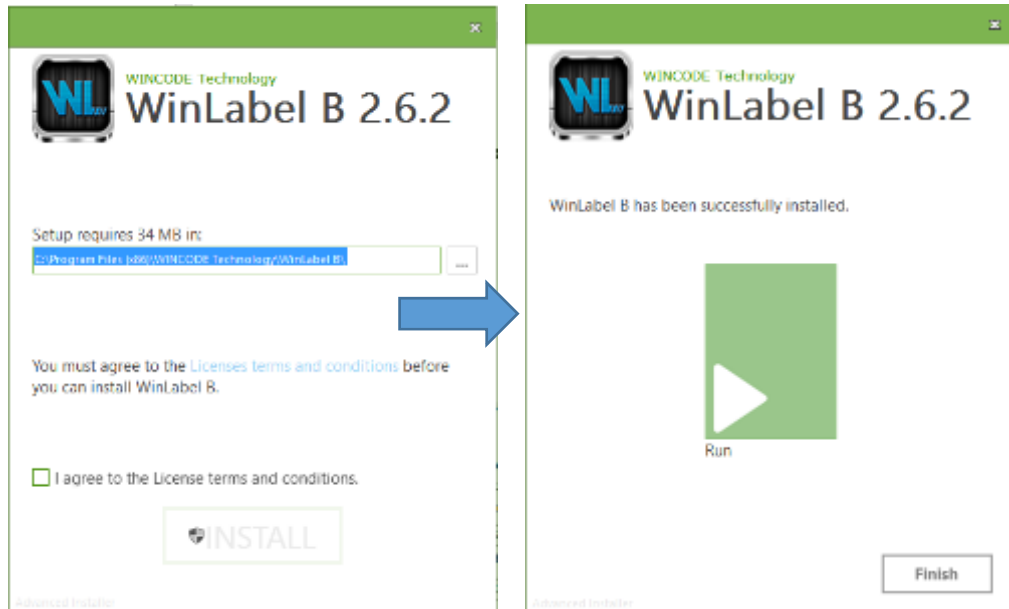

## 4.3 WINLABEL Label Editing Software

- The Welcome screen



- The main screen

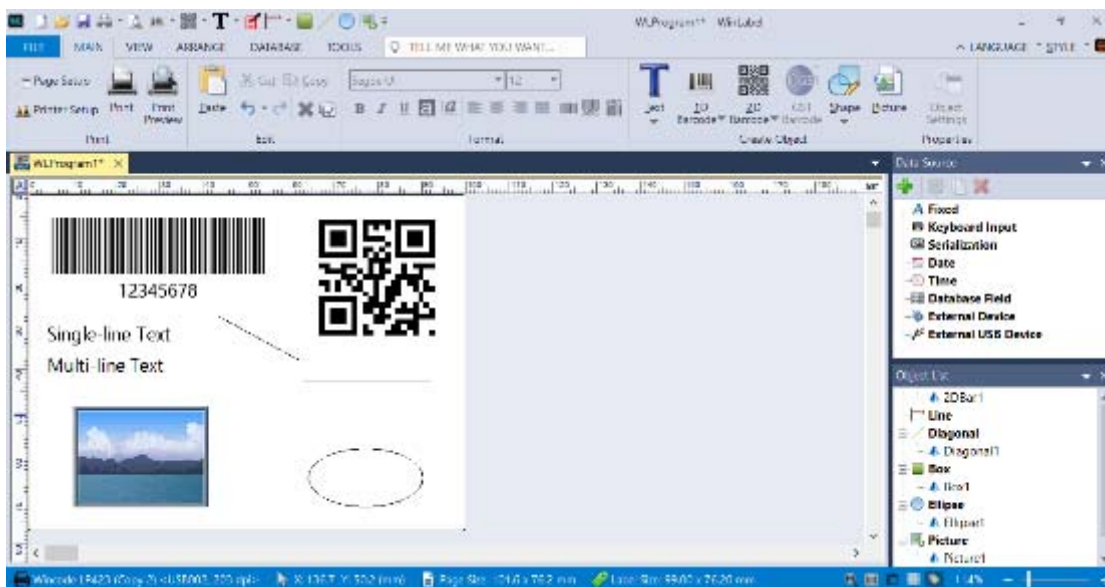

## 4.4 Update settings and update check

After entering the WinLabel program, click the “Update Check” icon in “TOOLS” page and check if it is the latest version. The program can be updated automatically. Besides, user can click “Update Settings” icon for adjusting the update settings

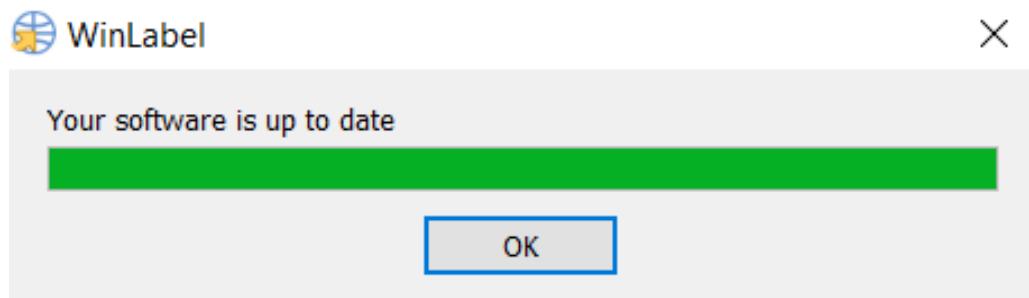
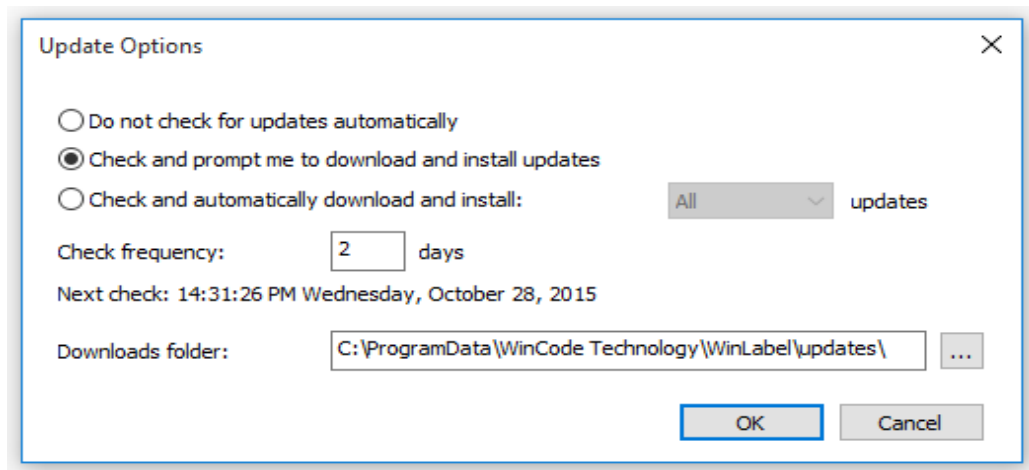
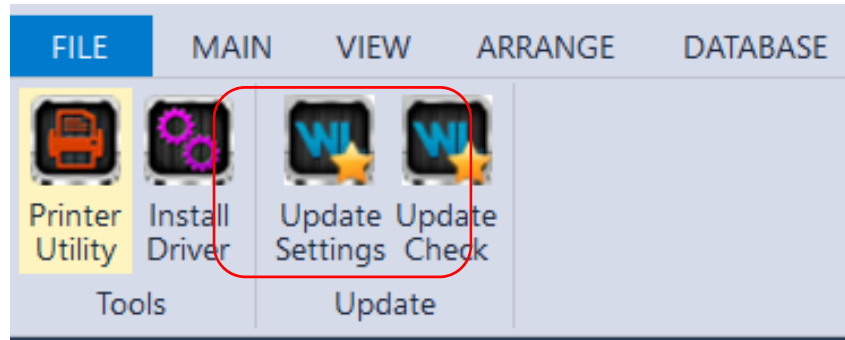

## 4.5 Firmware update Tool

- When user receives the \*.ulf FW file, please execute the file directly and the system will open the firmware update tool automatically. After confirming the version, please press “burn” and wait until the “update finished” information shown.
- The update procedure can be run with USB 、RS-232 、LPT 、Ethernet (USB is recommended.)
- Press the “Search” button when selecting Ethernet, the system will search the LAN network and list all the connecting printers.



Item	Description
Port	<ul style="list-style-type: none"> <li>• Term : select the connecting way: USB, RS-232, LPT, Ethernet</li> <li>• connect : select the connected printer.</li> </ul>
Firmware file	Confirm the firmware version <ul style="list-style-type: none"> <li>• The system will connect the firmware update tool automatically and show the information while executing the *.ulf file</li> </ul>
Burn	Burn the firmware into the printer
Get information	Get the serial number and the firmware version of the printer
Exit	Leave the firmware update tool

## 5. Printer Utility

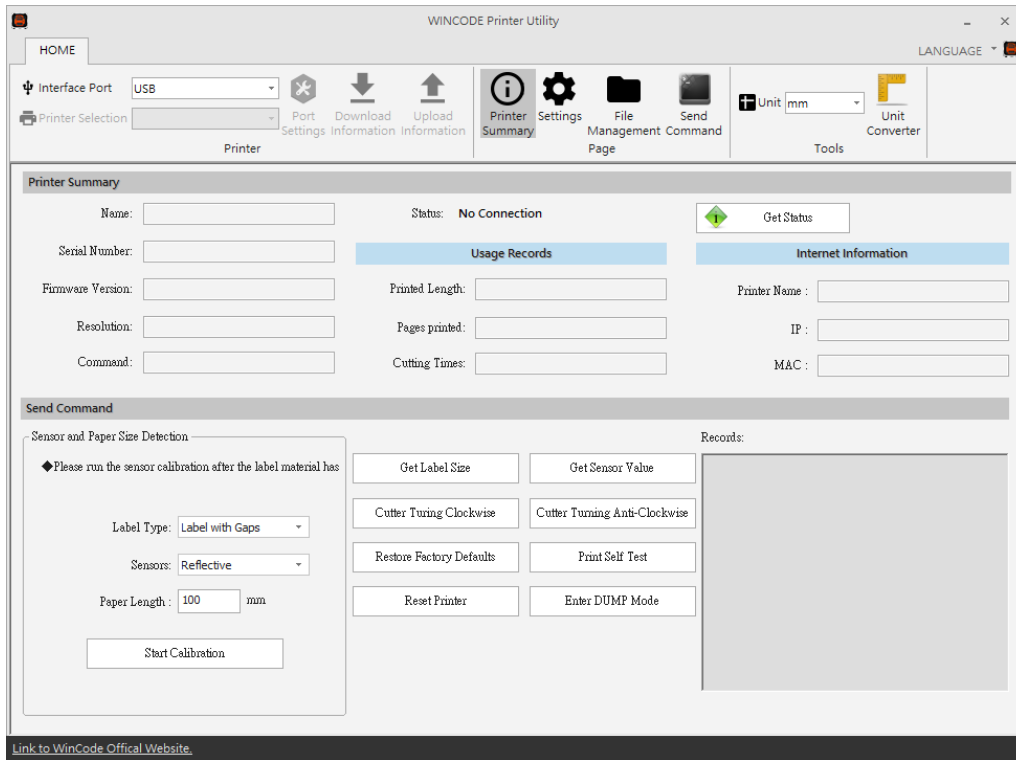

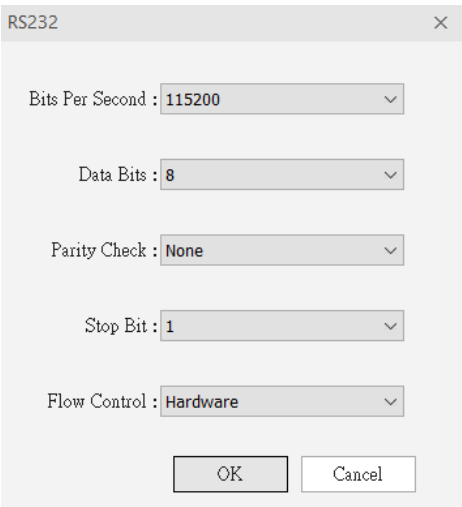

Item	Description
Interface port	Interface port selection: USB, RS232, LPT (Centronics), Ethernet.
Printer selection	While the printer is connected to the computer, the program can automatically detect the printer device. User can select a connected printer from the pulldown list.
Port settings	<p>When RS-232 or Ethernet is connected, select for interface settings</p> <ul style="list-style-type: none"> <li>RS-232: bps, data bit, parity check, stop bit, flow control selection.</li> </ul> 

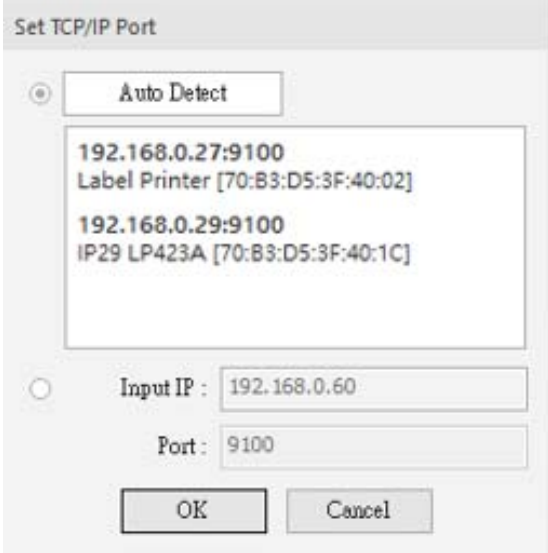

	<ul style="list-style-type: none"> <li>• Ethernet: auto or manual insert selection</li> </ul> 
<p>Download information</p>	<p>The current printer setting information can be showed in the Printer Summary area.</p>
<p>Upload information</p>	<p>The settings in the Printer Utility will be uploaded to the printer.</p>

## 5.1 Printing Summary

<p>Printer Summary</p>	<ul style="list-style-type: none"> <li>Listing printer information</li> </ul>  <p>Send Command window</p> <ul style="list-style-type: none"> <li>Start Calibration Run the sensor calibration after the label material has changed. If it is the same material but different size, only need to adjust the “Page Setup” at WinLabel. It is recommended to use “auto detection”.</li> <li>Get Label Size: get the detected value of label size at the right table</li> <li>Get sensor value: get the detected value of the sensors at the right table</li> <li>Cutter Turning Clockwise: cutter cuts label from top to bottom (Fully cut)</li> <li>Cutter Turning Anti-Clockwise: cutter cuts from bottom to top (Not completely cut-off the label, the user can tear off the label)</li> <li>Restore Factory Defaults: restore the parameters of the printer to factory default settings.</li> <li>Printer Self Test: print out the internal settings of the printer.</li> <li>Reset Printer: restart the printer             <ul style="list-style-type: none"> <li>Enter DUMP Mode: enter to the DUMP mode (Press “menu” for returning to the original mode)</li> </ul> </li> </ul>
<p>Settings</p>	<p>Please refer to the 3.5.2 Settings</p>
<p>File Management</p>	<p>Check the detail files in the different store spaces</p> 
<p>Send command</p>	<p>Be able to send command to the printer, please refer to the Printer Command Manual.</p>
<p>Unit- Tools page</p>	<p>Printing measurements: millimeter (mm), centimeter (cm), inch (in).</p>

## 5.2 Settings

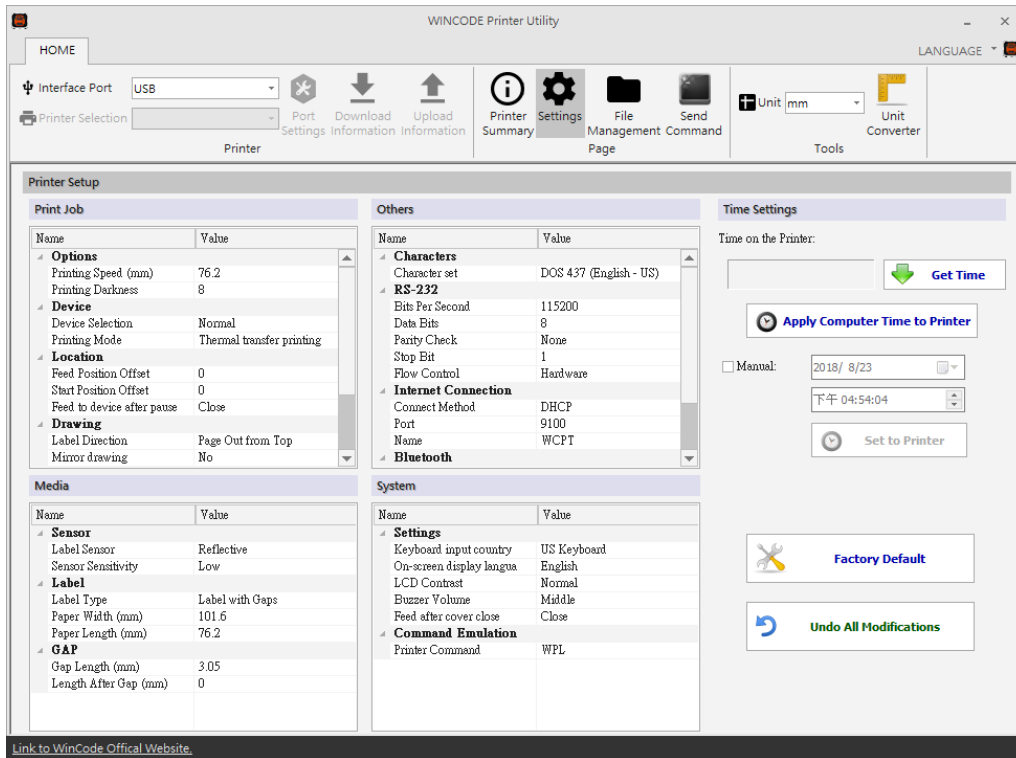

### 1) Print Job

Item	Description
Printing Speed (mm)	Select required speed
Printing Darkness	Select the required parameters from 0 to 15; adjust the temperature of the print head (8 is recommended for wax ribbon)
Device Selection	Normal, tear-off, peel-off and cutter modes are selectable.
Printing Mode	Direct Thermal and Thermal Transfer modes are selectable
Feed Position Offset (After printing)	Input the required parameters. (If the printer is connected to cutter/peeler, user may use this for offset settings. Default: 0)
Start Position Offset (Before printing)	Input the required parameters (Plus value feeds more distance; minus value back feeds more distance) * 203 dpi:8dot=1mm, 300 dpi:12dot=1mm
Feed to device after pause	Close: while pressing button, printer stop printing immediately. Open: while pressing pause button, printer will stop printing after completing the current label.
Label Direction	Label-out from the top or Label-out from the bottom
Mirror Drawing	No effect or mirror reflection.

Drawing origin X axis offset	Input the required parameters
Drawing origin Y axis offset	Input the required parameters

## 2) Media

Item	Description
Sensor-Label Sensor	Which sensor is using; Reflective / Transmissive selectable.
Sensor-Sensor Sensitivity	Low / Middle / High selectable.
Label-Label Type	Label with Gaps / Label with Black Line / Continuous label selectable.
Label-Paper Width	User can enter the parameter. (default: 4 inches)
Label-Paper Length	User can enter the parameter. (default: 3 inches)
Gap-Gap Length	User can enter the parameter. (default: 0.4016 inches)
Gap-Length after Gap	User can enter the parameter.
Label with Black Line-Black Line Thickness	User can enter the parameter. (default: 0.4016 inches) (Only when it is loaded the label with black line.)
Label with Black Line-Length after Black Line	User can enter the parameter. (Only when it is loaded the label with black line.)

## 3) Others

Item	Description
Characters	User can adjust the parameters.
RS-232	User can adjust the parameters when the port is RS-232.
Internet Connection	User can adjust the parameters while selecting "manual". Default: DHCP.
Bluetooth	User can enter the name and PIN code.

## 4) System

Item	Description
Setup-Keyboard Input country	Default: US Keyboard
Setup-On-screen display language	English, Traditional Chinese, Simplified Chinese, Spanish, Italian, Vietnamese, Korean.
Setup-LCD Contrast	Review the LCD contrast settings
Setup-Buzzer volume	Review the Buzzer volume settings in the printer
Setup-Feed after cover closed	Close / Open
Setup-label used up indication	Close / Open (Optional)
Setup-label length Error control	Close / Open, after selected, if the label size does not match the settings, the system sends the error report.
Printer Command	<b>Printer Emulation Switch</b> Auto Detect (Default), detect WPL, TSPL, ZPL, EPL, DPL automatically.

## 5) Time Setup

Item	Description
Printer Current Time	<ul style="list-style-type: none"> <li>Get the time: to get the current time of the printer.</li> <li>Synchronize the time of the computer to the printer.</li> <li>Manual setup: the user can setup the time of the printer.</li> </ul>
Reset to manufacturer default	Reset the printer to manufacturer default
Undo	Reset all the parameters to the original parameters, will not affect the setup in the printer.

### 5.3 File Management

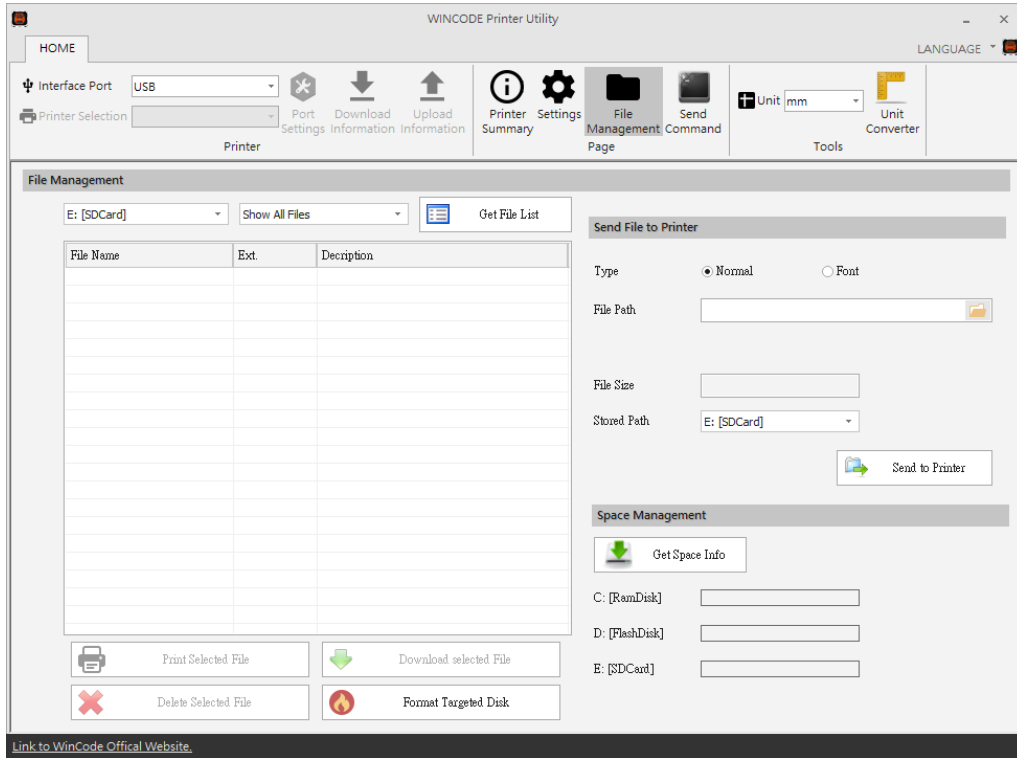

Item	Description
Get the file list	To get the file list from C:[RamDisk], D:[FlashDisk] or E:[SDcard]
Format the target disk	Initialize the disk
Delete selected file	Delete the selected files.
Download selected file	Download the selected files.
Print selected file	Print out the selected files.
Send the file to the printer	Send the selected files or font to the assigned storage area in the printer <ul style="list-style-type: none"> <li>File path: select the file that needed to be uploaded</li> <li>File size: show the size of the file automatically</li> <li>Storage location : select the storage location from C:[RamDisk] \ D:[FlashDisk] \ E:[SDcard]</li> </ul>

## 5.4 Send Command

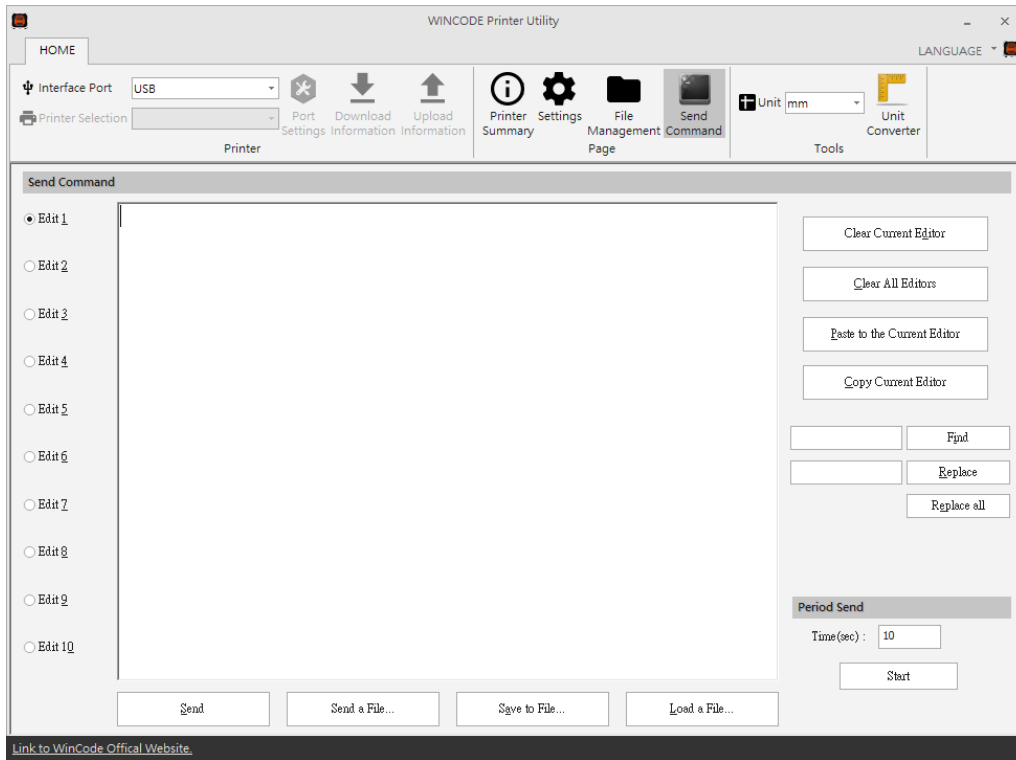

Item	Description
Edit Zone	<p>Edit the command</p> <ul style="list-style-type: none"> <li>• Clear the current edit zone : to clear the command in the current edit zone</li> <li>• Clear all the edit zone : to clear all the command in the edit zone</li> <li>• Paste to the current edit zone : paste the command to the current edit zone</li> <li>• Copy the current edit zone : copy the content in the edit zone</li> <li>• Search: search the specific content in the edit zone</li> <li>• Search and replace: replace the searched content</li> <li>• Replace all: replace all the assigned content from the edit zone</li> </ul>
Send	Send the command to the printer
Send the file	Send the file to the printer
Save the file	Save the command in the edit zone
Read the file	Read the file at the edit zone

## 6.LED indicators and button explanation



- LP4A models has two color LEDs to show the status (red and blue color) and four functional buttons. Please see the below explanation.



## 6.1 LED and button description

Ready – LED shows the blue light, Error – LED shows the red light

Press the Pause button to pause printing job. The red LED will be flash in the meanwhile.

Button/Light	Mode	Description
<b>Button 1</b> <b>MENU/EXIT</b>	Ready mode	Entering to the menu mode
	Printing Mode	No function
	Menu mode	Leave menu mode
<b>Button 2</b> <b>CANCEL/UP</b>	Ready mode	No function
	Printing Mode	Press once, cancel this error; Press twice, cancel printing job to return ready status
	Menu mode	Move up or forward
<b>Button 3</b> <b>FEED/ENTER</b>	Ready mode	Feed a label
	Printing Mode	No function
	Menu mode	Confirm option
<b>Button 4</b> <b>PAUSE/DOWN</b>	Ready mode	No function
	Printing Mode	pause printing
	Menu mode	Down or backward
<b>Red LED</b> <b>ERROR</b>	Red LED flash	Refers to all errors · e.g. motor, print head broken...etc.
<b>Blue LED</b> <b>POWER</b>	Blue LED always on:	ready status
	Blue LED flash	data transmission
<b>Flash red and blue LED</b>	Auto Run mode	Enter Auto Run

## 7.LCD menu description

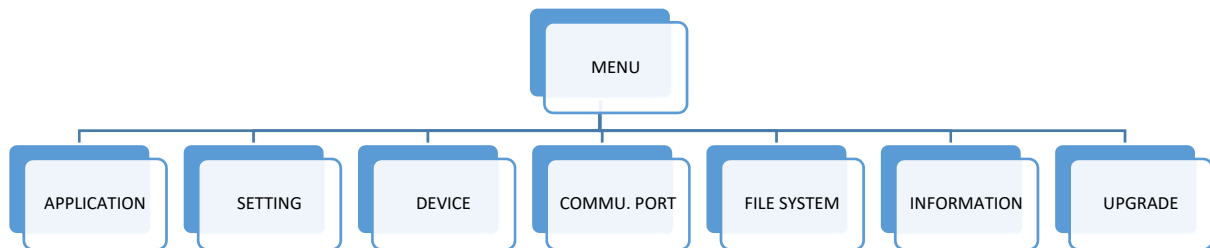

## 7.1 Program



Item	Description
SD card	<p>Need to insert a SD card in the printer first, and then download the file to the SD card in the printer with WinLabel.</p> <div data-bbox="454 790 1315 862" style="border: 1px solid #ccc; padding: 5px;"> <input checked="" type="radio"/> Send To Printer : <span style="border: 1px solid #ccc; padding: 2px;">SD Card (E:\)</span> </div> <p>Or to insert the SD card to the computer, select “save in SD card”. Mind to save the file under the subdirectory of WPL_Stuff. The subdirectory can be create itself or create automatically while SD car inserted.</p> <div data-bbox="486 1077 1294 1149" style="border: 1px solid #ccc; padding: 5px;"> <input type="radio"/> Save to File : <span style="border: 1px solid #ccc; padding: 2px;">gram Files (x86)\WINCODE Technology\WinLabel</span> <span style="border: 1px solid #ccc; padding: 2px 5px;">Browse...</span> </div>
Flash Disk	<p>Design the label on the WinLabel and then use “Download” function to download the standalone files to the Flash ROM of printer. The file in the flash disk will not be deleted if printer turns off the power</p> <div data-bbox="454 1368 1251 1440" style="border: 1px solid #ccc; padding: 5px;"> <input checked="" type="radio"/> Send To Printer : <span style="border: 1px solid #ccc; padding: 2px;">Flash ROM (D:\)</span> </div>
RAM Disk	<p>Design the label on the WinLabel and then use “Download” function to download the standalone files to the RAM Dish of printer. The file in the ram disk will be deleted if printer turns off the power</p> <div data-bbox="454 1659 1262 1731" style="border: 1px solid #ccc; padding: 5px;"> <input checked="" type="radio"/> Send To Printer : <span style="border: 1px solid #ccc; padding: 2px;">RAM (C:\)</span> </div>

## 7.2 Setting



Item	Description	Manufacturer Default
Label	<ul style="list-style-type: none"> <li>Label calibration: User can use this function to measure the label height and gap height.</li> <li>Sensor calibration: Please run the sensor calibration after the label material has been changed.</li> <li>Label Type: Gap, Black line, Continuous types of label</li> <li>Sensor Type: Transmissive or Reflective</li> <li>Start Line: Input -99 ~ +99 required parameters</li> <li>Feed Offset: Input -99 ~ +99 required parameters</li> <li>X Shift : Input -99 ~ +99 required parameters</li> <li>Y Shift : Input -99 ~ +99 required parameters</li> <li>Factory default : The parameters of printer will be factory default setting.</li> </ul>	<ul style="list-style-type: none"> <li>Label type: Gap</li> <li>Sensor type: Reflective</li> <li>Start line: +00</li> <li>Feed Offset: +00</li> <li>X shift: +00</li> <li>Y shift: +00</li> </ul>
Printer	<ul style="list-style-type: none"> <li>Density: Input required parameters 0-15</li> <li>Speed: Input required parameter 1-5 ips depended on the model type</li> <li>Thermal Mode: Thermal Transfer or Direct Thermal</li> <li>After Print: Tear off mode, Peeler mode, Cutter mode, Normal mode</li> </ul>	<ul style="list-style-type: none"> <li>Density: 5</li> <li>Speed: 3</li> <li>Thermal Mode: Thermal Transfer</li> <li>After Print: Tear off mode,</li> </ul>
UI	<ol style="list-style-type: none"> <li>LCD : Choose the required language on the LCD</li> <li>Keyboard Language: Choose keyboard input language</li> <li>Contrast: Set up the degree of contrast on the LCD</li> <li>Beep Volume: Adjust the volume of buzzer</li> </ol>	<ul style="list-style-type: none"> <li>LCD: 2</li> <li>Beep Volume: 3</li> </ul>
Emulation	Select the emulated printing language	Auto
Reset	Reset to manufacturer default mode.	

## 7.3 Device



Item	Description
Keyboard	Keyboard 、 Scanner connectivity testing status (Suitable for HID device)
Time&Clock	Press (FEED) button to choose (12HR/24HR) 、 Hour 、 Minute
Cutter	Select Forward cut or Reverse Cut mode
Peeler	Press FEED button to peel label for testing
Dump Mode	Enter to the dump mode (Press MENU button to return the ready mode)
Dump (57mm)	After entering, receive the information and print it on 57mm label, this mode is for scale connection. (Press "menu" to return to the original mode.)

## 7.4 Communication Port



### 1) RS-232 (commu. Port)

Item	Description	Manufacturer Default
Baud Rate	Depends on the connected device to choose baud rate ( 4800/ 9600/ 19200/ 38400/ 57600/ 115200/ 230400 bps)	9600
Data Bits	Select 7 or 8(default)	8 bits
Parity Check	Select No Parity, Odd Parity, Even Parity	No Parity
Stop Bits	1 bit or 2 bits	1-bit
Flow control	Hardware / None	Hardware
transport Test	When device has been connected, user can transfer the parameters of device to the printer	

### 2) Ethernet

Item	Description	Manufacturer Default
IP mode	Static-IP or DHCP	Static-IP
IP address	IP Address setup	192.168.101.128
Subnet mask	Subnet mask setup	255.255.255.0
Gateway default	Gateway default setup	192.168.101.1
Port number	Port number setup	9100
MAC address	Show Ethernet ID information	
Reset	Reset to manufacturer default	

### 3) Bluetooth (BT)

Item	Description	Manufacturer Default
Bluetooth Name	Setup the name of Bluetooth	BT-SPP
Bluetooth PIN code	Bluetooth PIN code setup	

## 7.5 File System

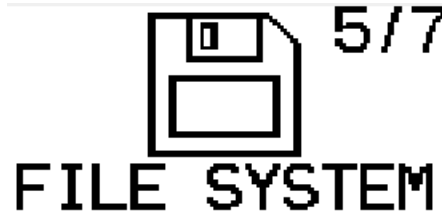

Listing the file details in the SD card or Flash disk or RAM disk

Item	Description
Disk Management	SD card, Flash Disk, RAM Disk selectable; search the file and system information; delete the file
SD information	Shown the used space, free space, all space of the SD card
Flash information	Shown the used space, free space, all space of the Flash Disk
RAM information	Shown the used space, free space, all space of the RAM Disk

## 7.6 Information



Item	Description	Manufacturer Default
Version	List the current firmware version	
Serial Number	List the product serial number	
Emulation	List the current printing language	Auto
Printed Labels	How many labels have been printed	0
Printed Distance	How many label length has been printed	0 M
Cut Count	How many cuts have been happened	0 pcs
Resolution	203 Dpi or 300 Dpi in this printhead	

## 7.7 Upgrade



Place the updated firmware in the WPL\_Stuff folder of SD card, and take this SD card inserting to the printer, then use this Upgrade option to click the selected file to confirm the updated procedure.



## 8. Standalone printing

### 8.1 Feature

This function provides a standalone operation without use the computer. Eliminating the burden of the PC to complete the requirement to print labels after a simple data input.

This function has the following characteristics :

- No need to connect computer for label printing
- SD card can easily store thousands of standalone files
- Connecting keyboard to input the variable data
- Built-in Real-time clock for date coded labelling
- The diversity of external device connection (keyboard, scanner, and scale...etc.)
- Simplify the processes, printing label anytime and anywhere
- No need to write computer codes to create file
- Store thousands of standalone programs in different multiple language file names in the printer
- Provide a string combination from the multiple information and do arithmetic
- Free bundled labeling software for making standalone program file

※Diagram :



※Bundled labeling software for making standalone program file :

- Provide a string combination from the multiple information (ex. Serial number + data + external input weight...etc.)
- Provide a variety of dynamic data processing for each variable field (ex. Discard text from left, keep numbers only, to upper case...etc.)
- Provide a variety of device input for each variable field (ex. Scale, RS232 interface, date, keyboard, scanner...etc.)
- External input data can execute arithmetic directly (+ - x / %, round off, kilogram into pound...etc.)
- Standalone program file can be easily done by setting parameters on the Winlabel. No need to write computer codes to create file anymore



**WINLABEL**





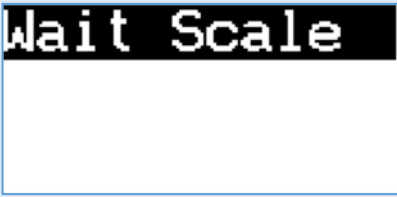
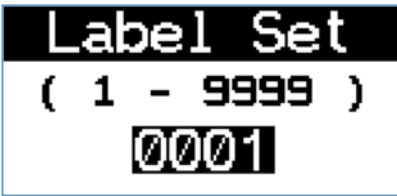
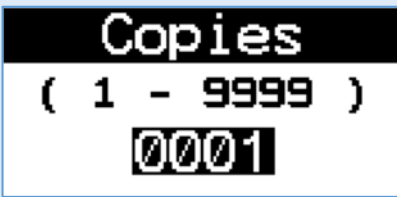

## 8.2 User Interface

LCD screen	Description
	<p>Main menu : Display the built-in Real-time clock. if time are incorrect, it can change the battery or the insulating strip doesn't remove.</p> <p>  : the printer is already connecting with keyboard or scanner.   : the SD card is inserted in the printer.         </p>
	<p>Press the button 1 to enter to the menu mode. The first item is "APPLICATION". It's the entry point of standalone operation.</p>
	<p>Standalone file has 3 sources. There are SD card, Flash disk, and RAM disk. Depending on the size of the memory space to decide the number of store files, currently support 512 filed.</p>
	<p>Display the file list when enter the source. User can use keyboard or scanner to search the file name.</p>
	<p>This is the "keyboard input" standalone operation interface. The black part is the prompt text, it supports multiple language, the input section currently supports English and numbers.</p>
	<p>This is the "number series" standalone operation interface. The black part is the prompt text, it supports multiple language, the input section currently supports English and numbers.</p>

	<p>This is the external device standalone operation interface; it can enter data by RS232. The black part is the prompt text, it supports multiple language.</p>
	<p>Label set: when use serial number, it will ask user to enter.</p>
	<p>Label copies: It will display before the software download the file, select "prompt to enter quantity when print".</p>

## 8.3 Hardware notice

### 8.3.1 Equipment Introduction

Equipment	Application
	<p>Label printer: As the reception or internet RS-232 USB Host interface, so that the operation is no longer using a computer to complete the data collection, and print the label after edit the data.</p>
	<p>The electronic scale has RS-232 port, and can input the weight.</p>
	<p>Numeric keyboard connects to printer by USB port for enter variable data.</p>
	<p>DB9: connect the scale to printer.</p>
	<p>Null Modem: Convert the data line, electronic scale and printer can pass.</p>
	<p>SD card: It can save thousands of standalone file and other related document. The file system must be FAT32 and saving menu is "WPL_Stuff".</p>

### 8.3.2 Printer Ports Introduction



USB Host: Connecting USB keyboard and scanner

RS-232:  
Connecting USB scanner or other device have RS-232 port

The power consumption of the external device does not exceed 5V / 1.0A. If the USB host needs to connect to multiple devices at the same time, we recommend to use self-power hub.

### 8.3.3 Printer RS-232 pin assignment

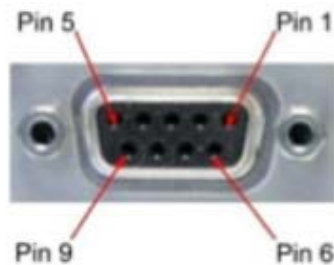

Pin	Define	Description
1	DCD	Data Carrier Detected
2	TXD	Transmit Data
3	RXD	Receive Data
4	DSR	Data Set Ready
5	GND	Signal Ground
6	DTR	Data Terminal Ready
7	CTS	Clear to Send
8	RTS	Request to Send
9	RI	Ring Indicator

### 8.3.4 Printer serial port with electronic scales pin assignment

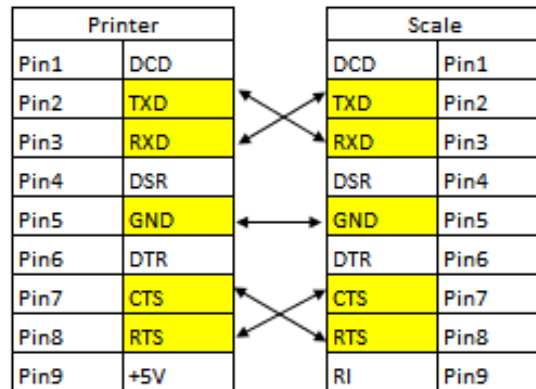

Printer connect to external device is RXD and TXD connect each other and have the same Baud Rate in generally.

### 8.3.5 Printer serial port with RS-232 scanner pin assignment

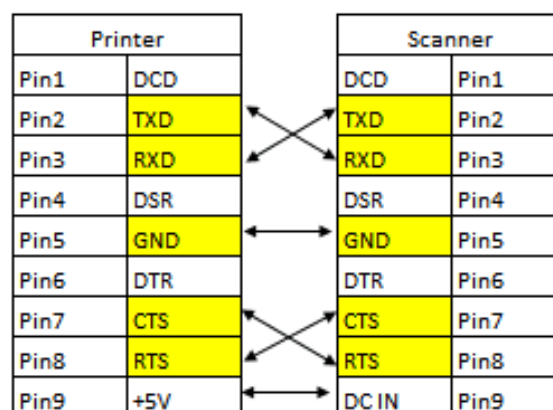
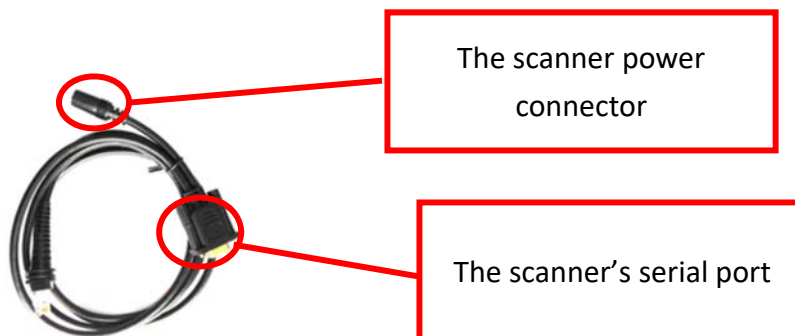

Connected printer to RS-232 by Use printer in pin 9 DC+5V and set same Baud Rate. If the scanner pins 9 is DC+5V input, it doesn't need external power.

### 8.3.6 External device

Keyboard	Numeric keyboard	Scanner
		
Counter	Length measuring meter	Mechanical arm
		
Pricing scale	Scale on the ground	Table Scale
		
Paint tinting machine	Chromatic aberration machine	PLC
		

### 8.3.7 How to contact printer electronic scales

- 1) Prepare the printer, electronic scale, cable, and null modem.



- 2) The electronic scale connected to printer by cable and null modem.





- 3) Enter printer menu, select "COMMU. PORT" to perform data transmission test. The preset Baud Rate of printer is 115200 bps; electronic scale is 9600 bps. Please change printer baud rate to 9600 bps.

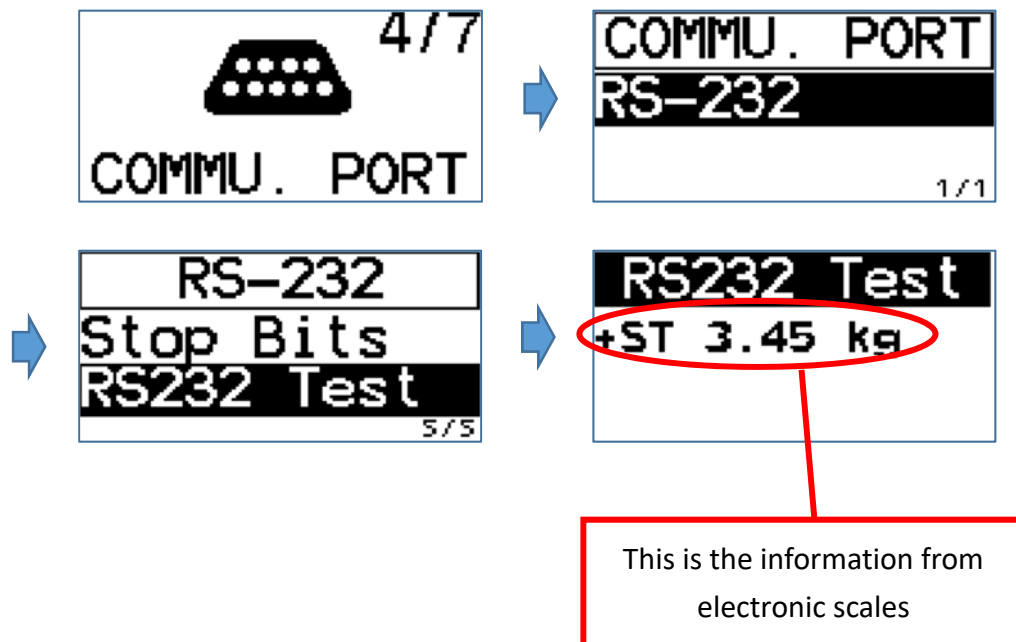

- 4) If electronic scale output data are too much or include special characters, it can use HyperTerminal to capture RS-232 port data.

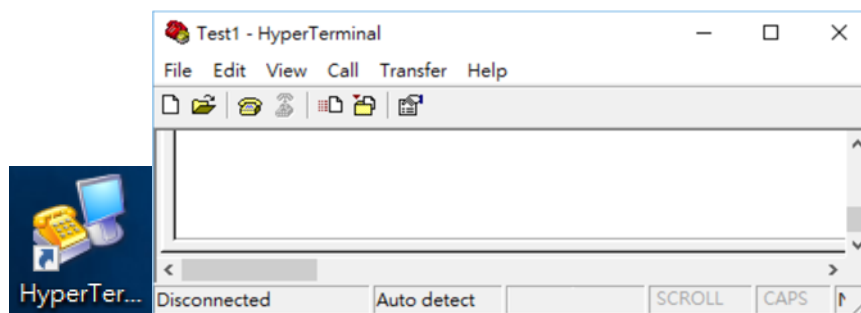

HyperTerminal official website :

<http://www.hilgraeve.com/hyperterminal/>

HyperTerminal trial version website :

<http://www.hilgraeve.com/hyperterminal-trial/>

HyperTerminal video :

<https://www.youtube.com/watch?v=n8p2zb3KRO8>

## 8.4 Operating procedures

### 8.4.1 Standalone operating procedures diagram

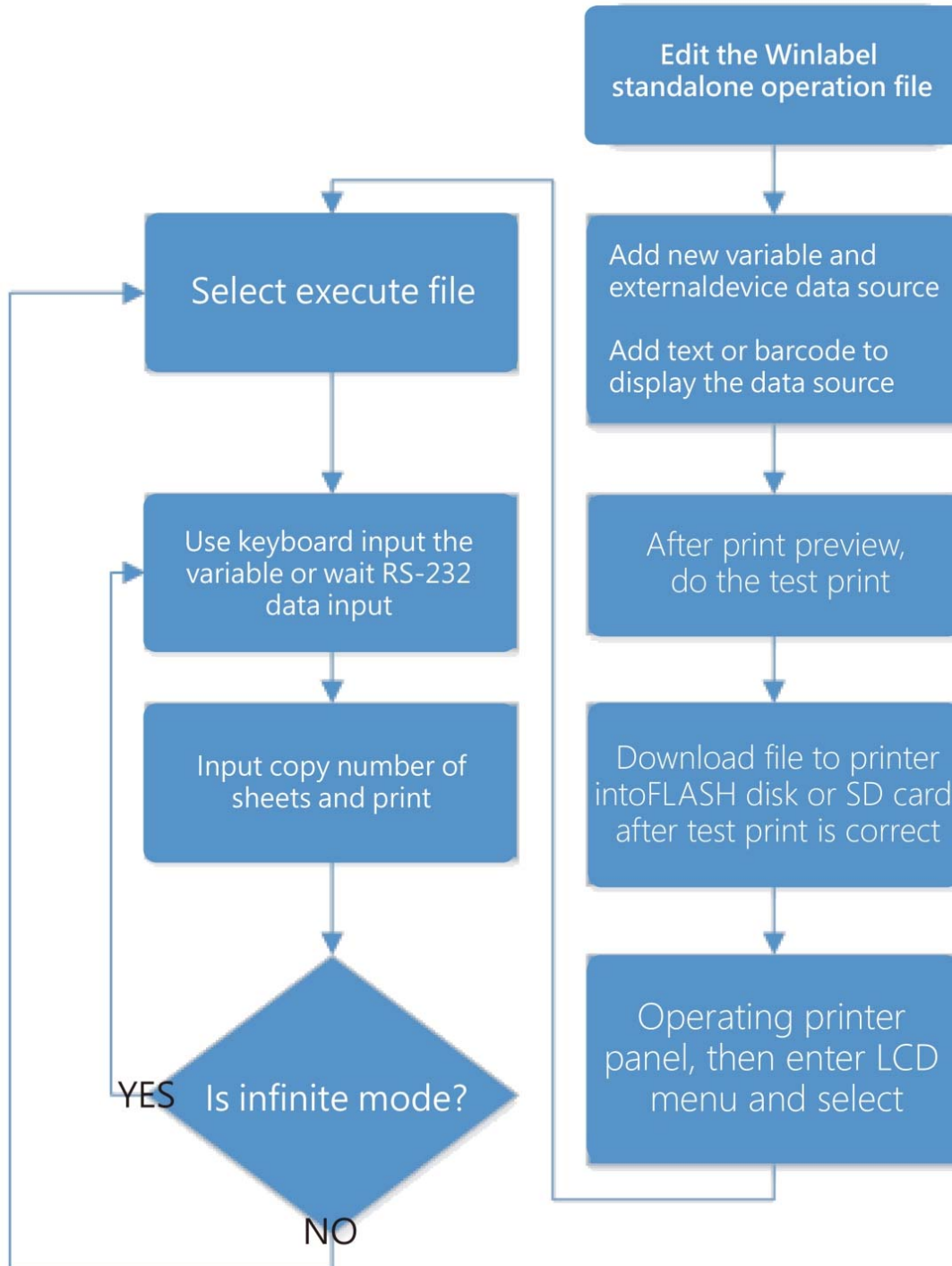

## 8.4.2 How to make a standalone file

- 1) Please install the new Winlabel software and driver. Then open Winlabel program.



- 2) Click the new label, then select a printing method and WLP format.

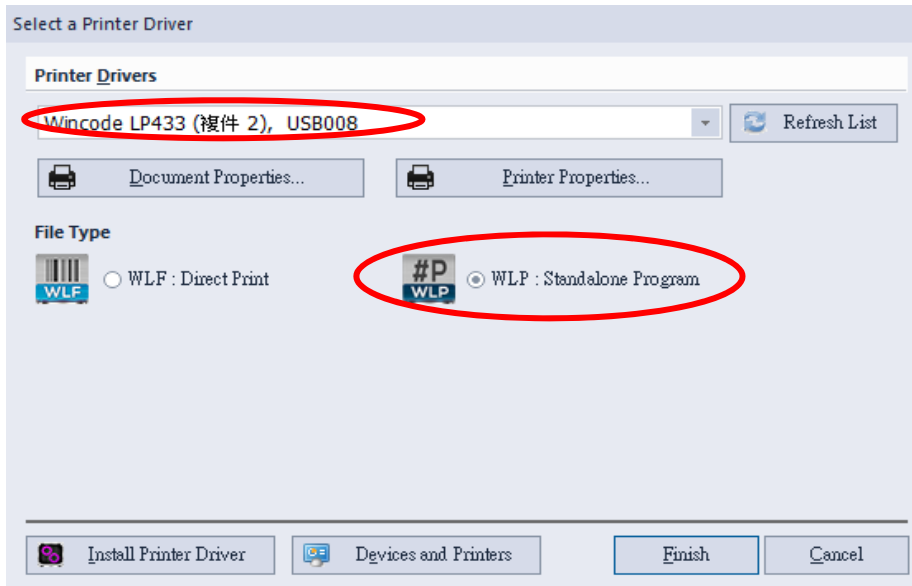

- 3) Measure the label size first, and setup in "page setup". Please note the size of gap and black mark.

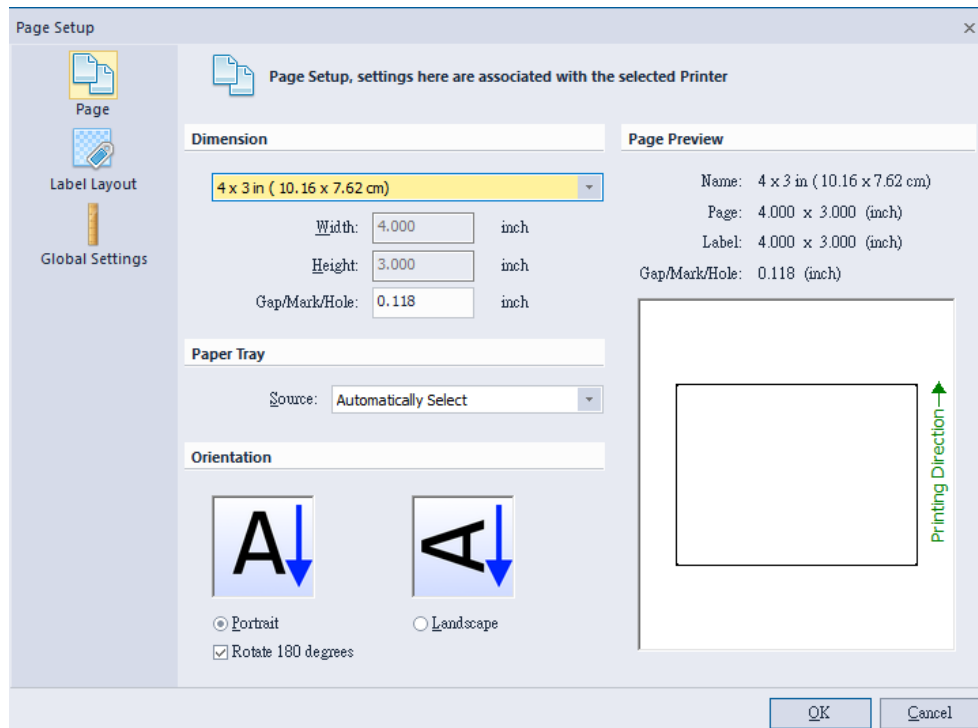

4) Then appears operating interface.

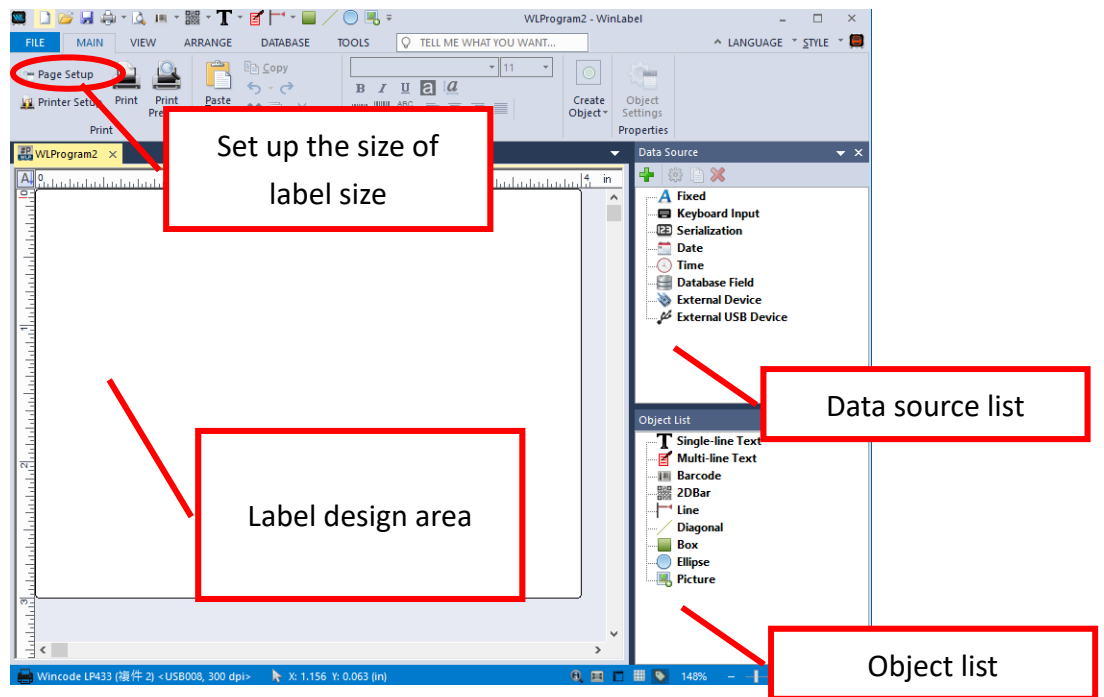

5) The variable data, we use in standalone operation will show in the “Data Source”.

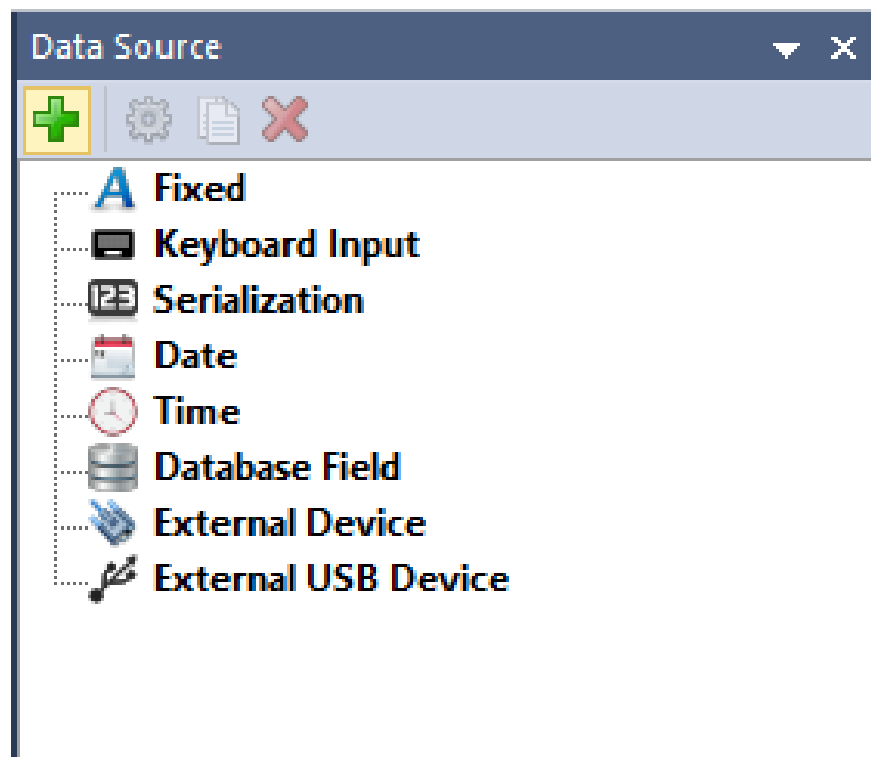

6) We demonstrate an external input device example.

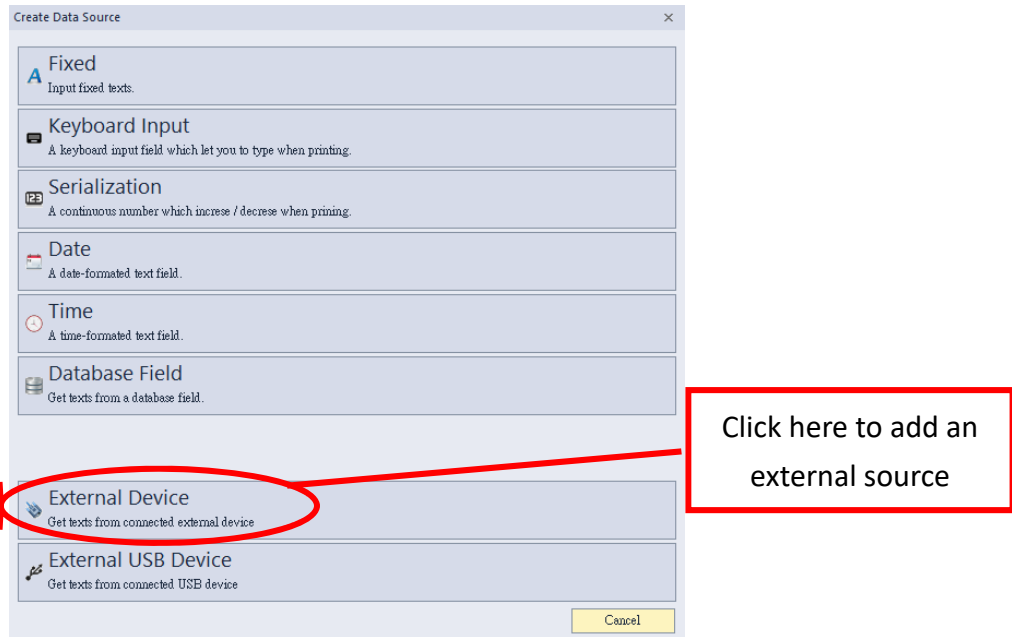

7) Click "External Device" and then appear the dialog as below.

- Prompt Text: It will display on the LCD screen when use standalone operation and can be any language.
- Sample Text: Simulates RS232 received data, which will facilitate to confirm the information you want when typesetting.

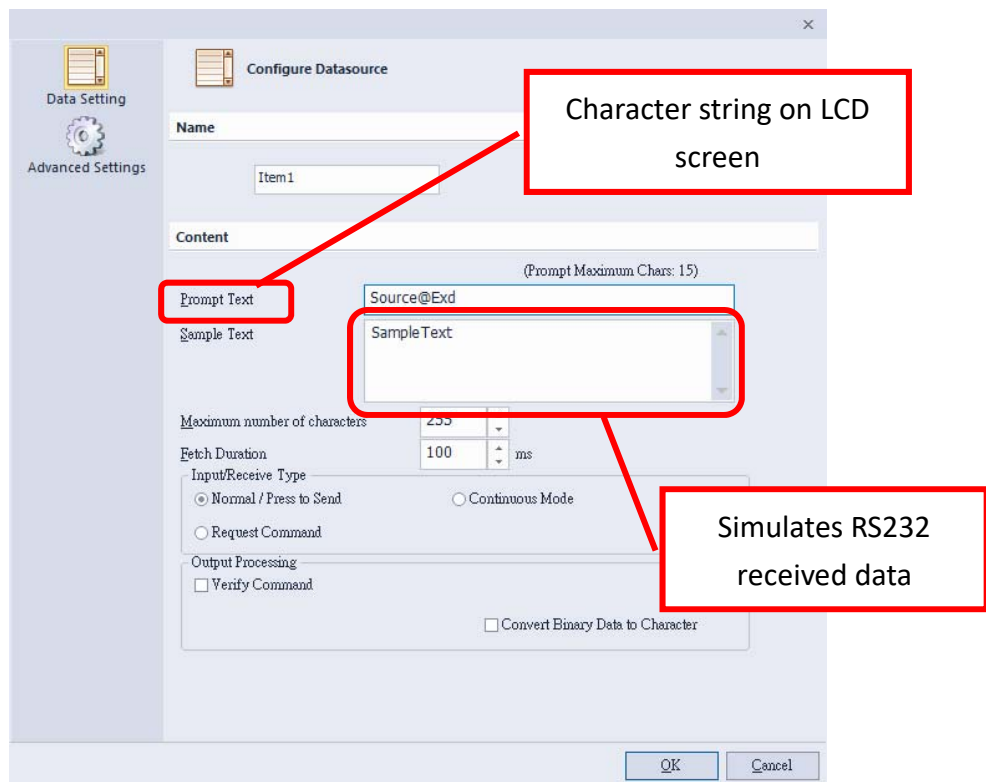

8) The user can add “external USB device” to get information through the connected USB scale.

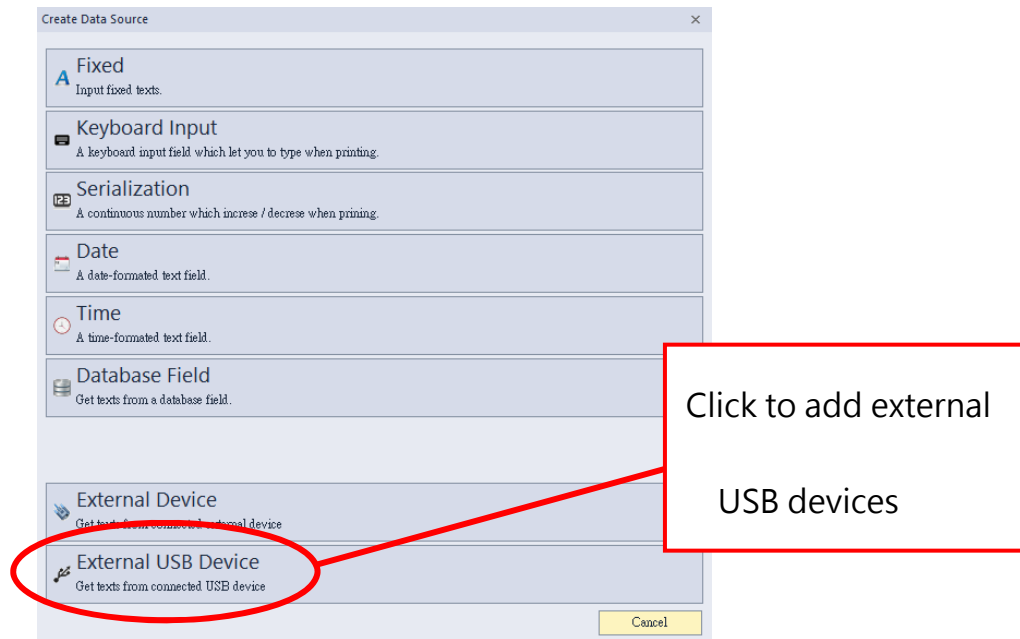

9) Click “external USB device”, the following window will pop out:

- “Hint character string” is the character string that shown on the LCD screen while the standalone printer operating, it can be any language of character string.
- “Sample character string” can simulate the document that received by USB. It makes typesetting easier.

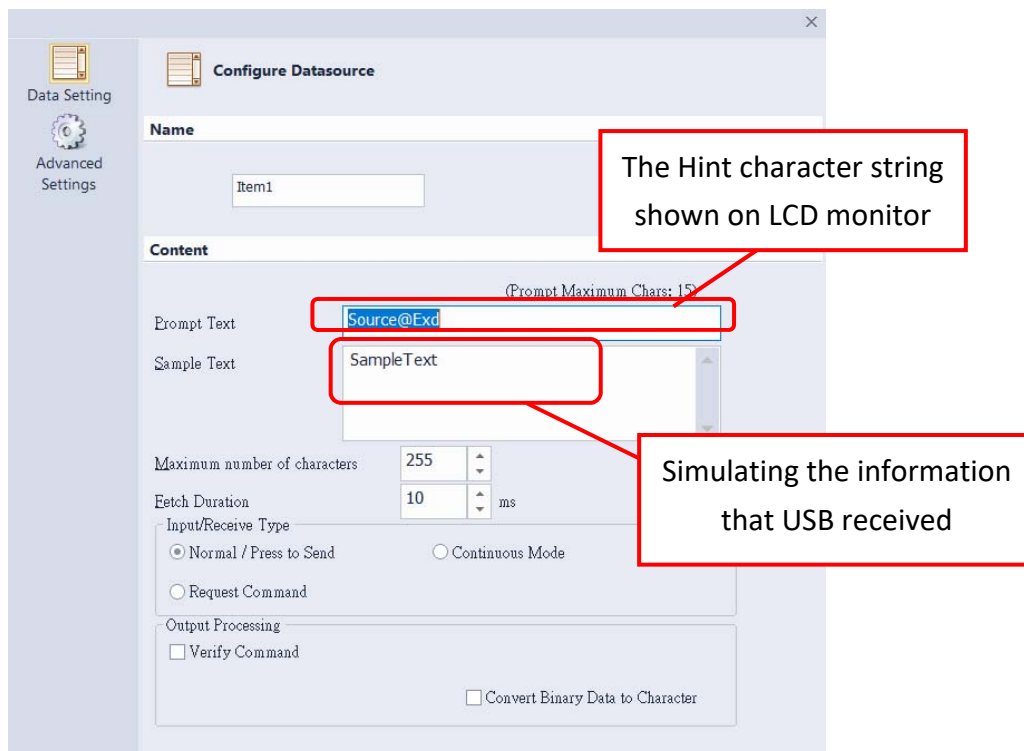

10) For example, RS-232data input's 3.45 kg", LCD screen display "Wait Scale" ◦

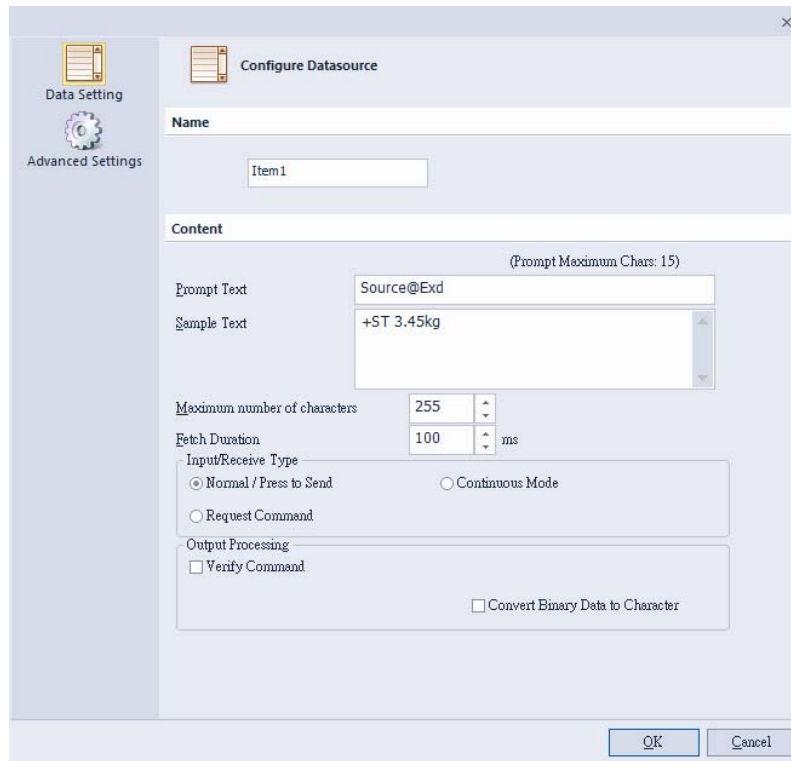

11) Then make typesetting object to take the data source.

- Object list as below
- Currently only supports "Single-line Text", "Barcode", and "2DBar".

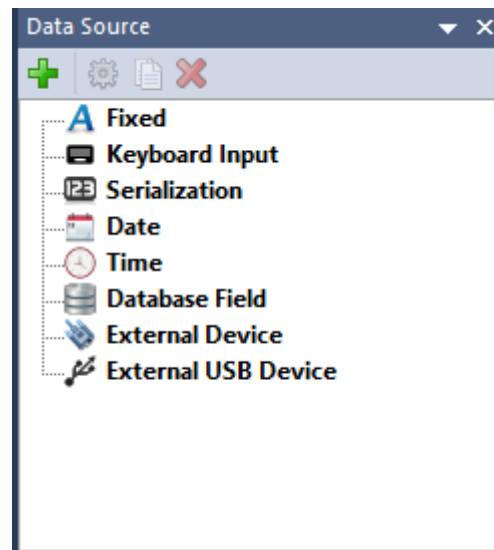

12) User can produce the object by using functional zone.

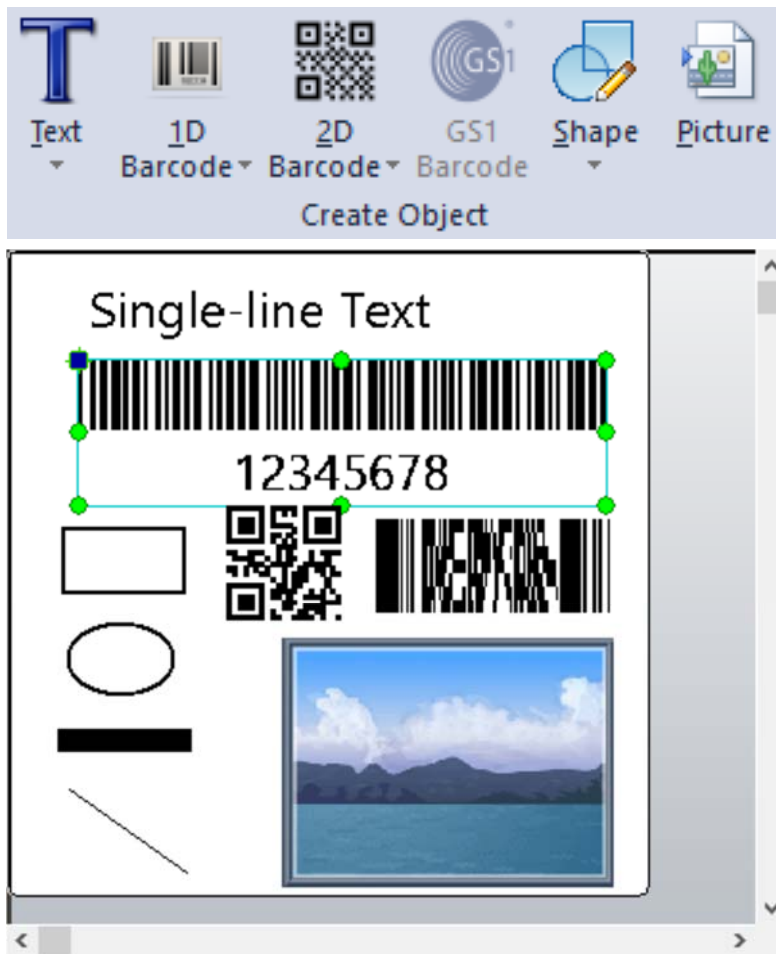

13) First select "Single-line Text"

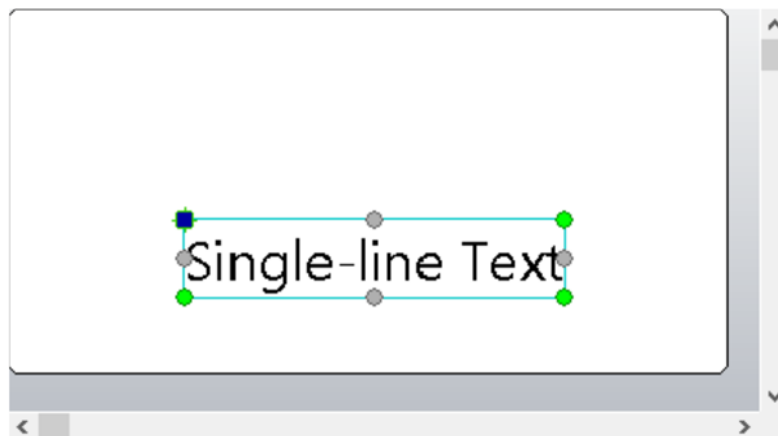



- 14) Click the object twice to enter the dialog as below. Select “Variable Data” and choose variable to add to data list. Data list can add multiple source as a result of a string of sequential combination.

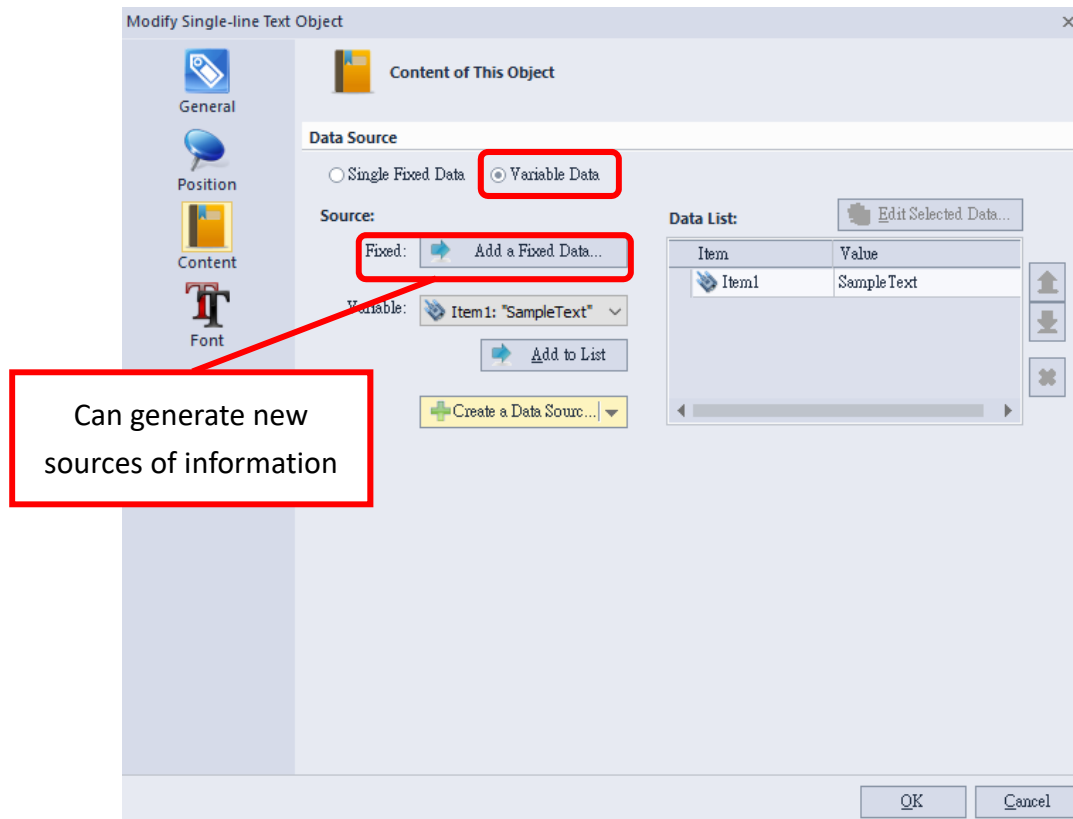

- 15) After confirm the data sources, the object data will change to the select sources immediately. If the data doesn't we want, ex." +ST 3.45 kg" change to"3.45", it must conduct "Advanced Settings".

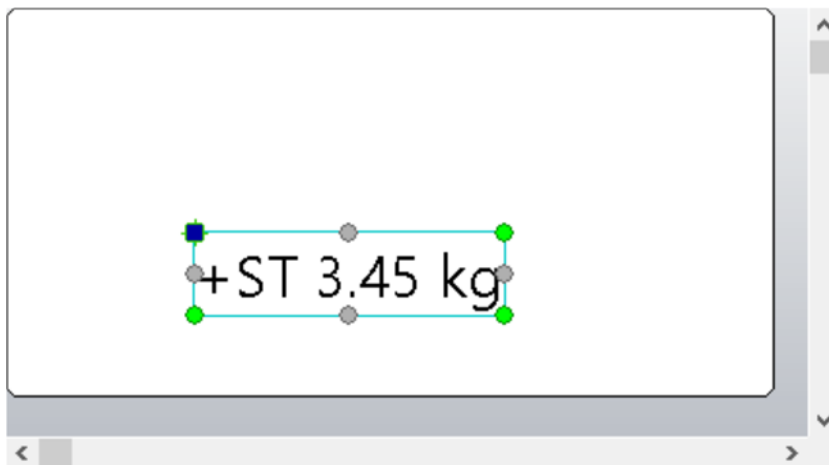

- 16) Click object twice, enter the dialog as below. Select the item in a “Data List” and then click the “Advanced” button.

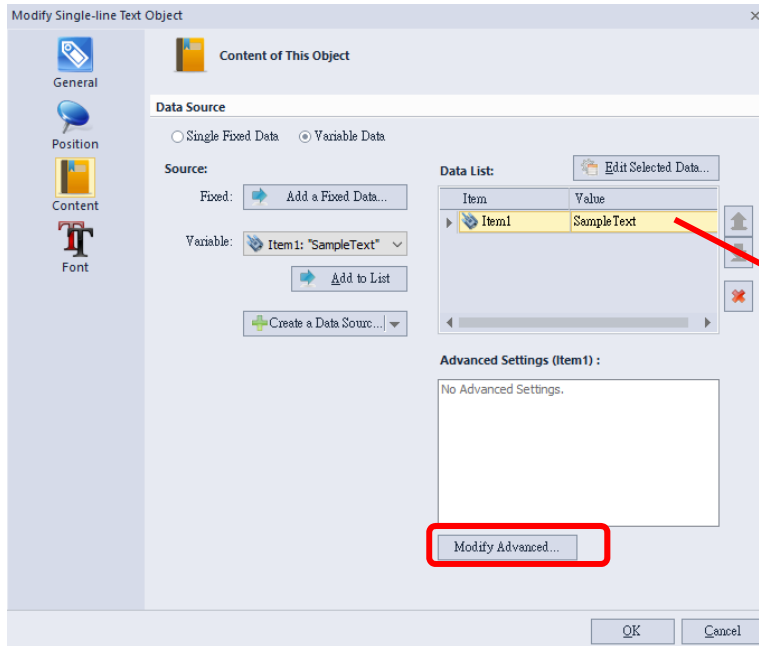

Click the item first and appear the button beneath the dialog.

- 17) This is “Advanced Option” dialog as below. We will add two truncation order, respectively “Discard texts from left:4” and “Discard texts from right:3”.
- Currently divided into three categories, “Truncation”, “Arithmetic”, and” Format”. Every category has a number command functions. It will continue to increase command functions in the feature.
  - The list can freely add or delete items, and you can adjust the order of execution. The top one exclusive first.

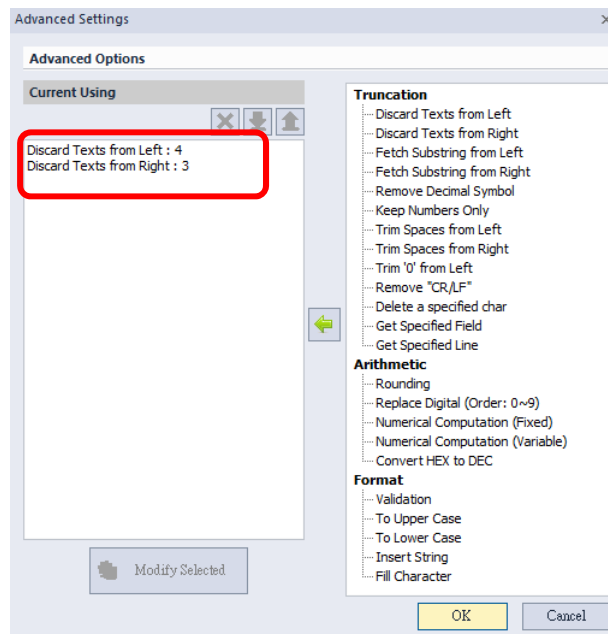

- 18) Finish setting “Advanced Option” and then see the “Advance settings” list the item. It is easy to use with queries; it will be based on the contents of the source object transformation.

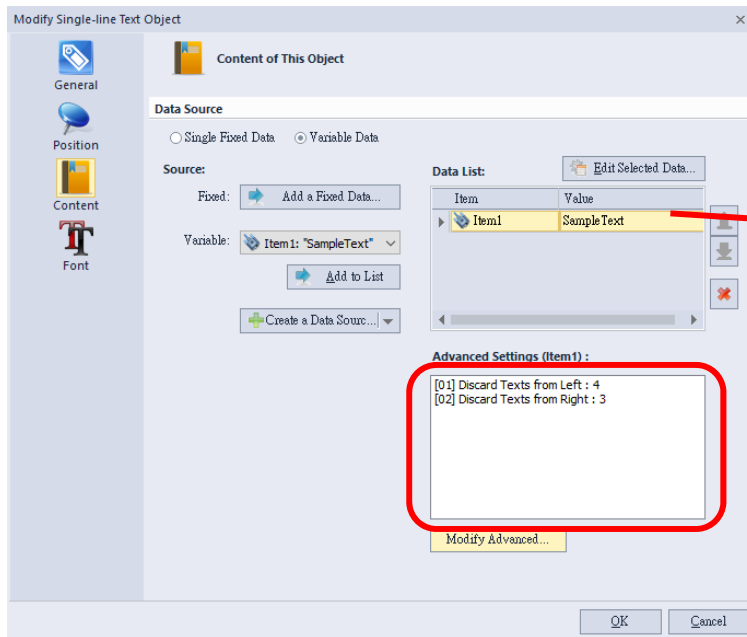

- 19) After finish setting “Advanced Option”, the result consistent as we need, if not correct, you can use the advanced process adjusted to the desired requirements.

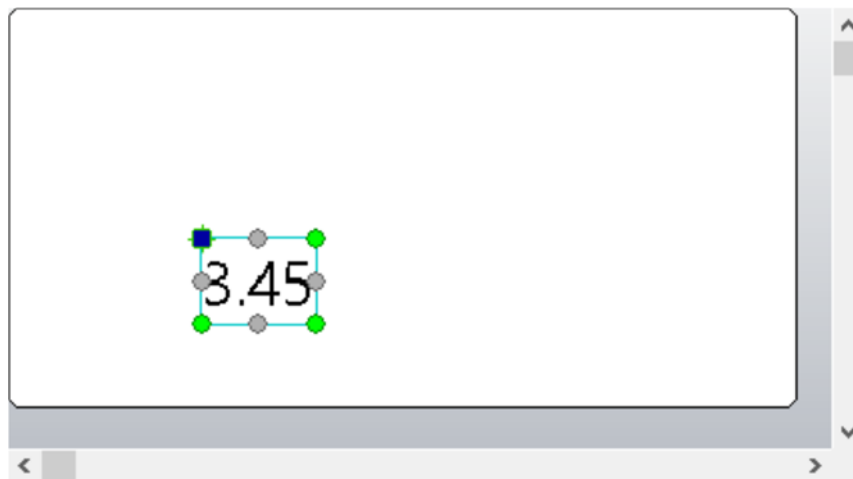

20) Then we make “keyboard input” variable.

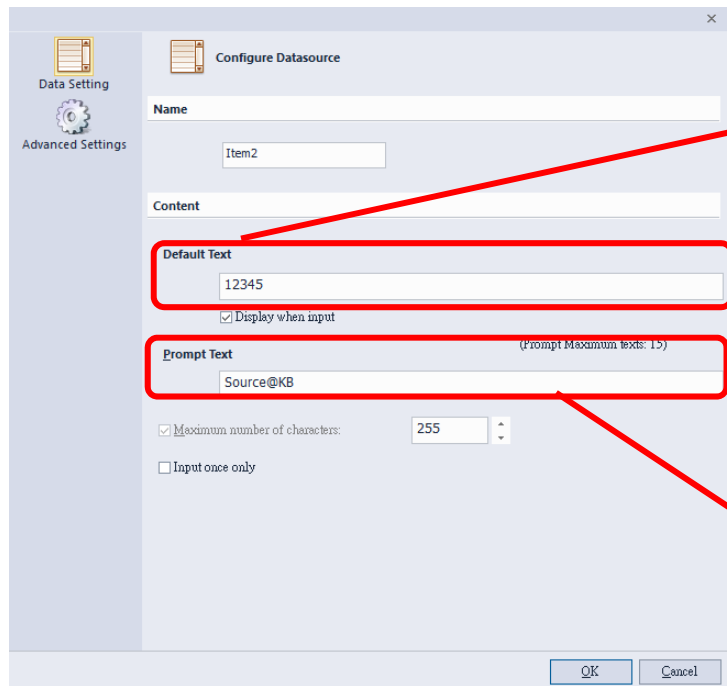

The screenshot shows the 'Configure Datasource' dialog box with the following settings:

- Name: Item2
- Content: (empty)
- Default Text: 12345
- Display when input:
- Prompt Text: Source@KB (Prompt Maximum text: 15)
- Maximum number of characters: 255
- Input once only:

Two red callout boxes provide instructions:

- Box 1: Enter the string displayed on the LCD screen previously. (Points to the Default Text field)
- Box 2: Prompt text displayed on the LCD screen. (Points to the Prompt Text field)

21) Then we make the “serial number” variable.

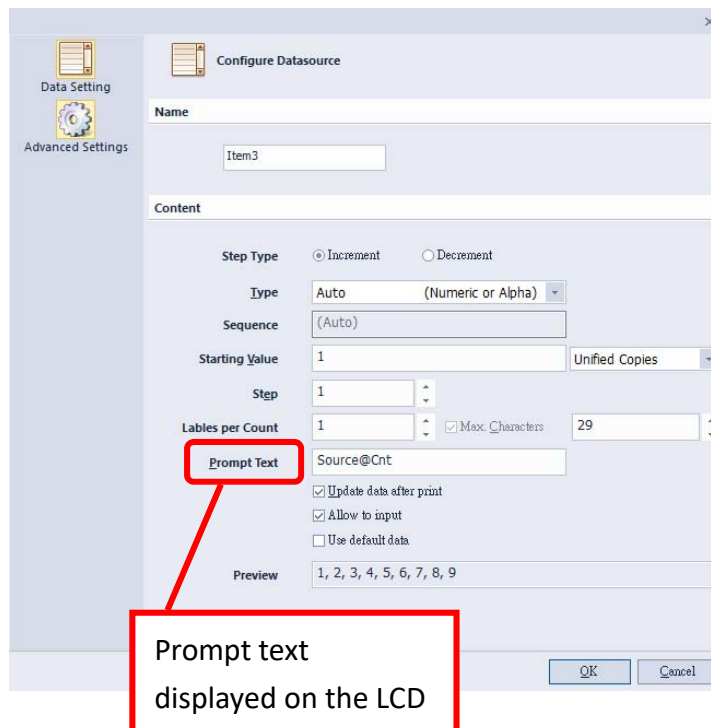

The screenshot shows the 'Configure Datasource' dialog box with the following settings:

- Name: Item3
- Content: (empty)
- Step Type:  Increment  Decrement
- Type: Auto (Numeric or Alpha)
- Sequence: (Auto)
- Starting Value: 1
- Step: 1
- Labels per Count: 1
- Max. Characters: 29
- Prompt Text: Source@Cnt
- Update data after print:
- Allow to input:
- Use default data:
- Preview: 1, 2, 3, 4, 5, 6, 7, 8, 9

Two red callout boxes provide instructions:

- Box 1: Prompt text displayed on the LCD (Points to the Prompt Text field)
- Box 2: Prompt text displayed on the LCD (Points to the Preview field)

22) We make a “Barcode” object, the data source is “keyboard input” and” serial number”. It is “barcode” setting as below.

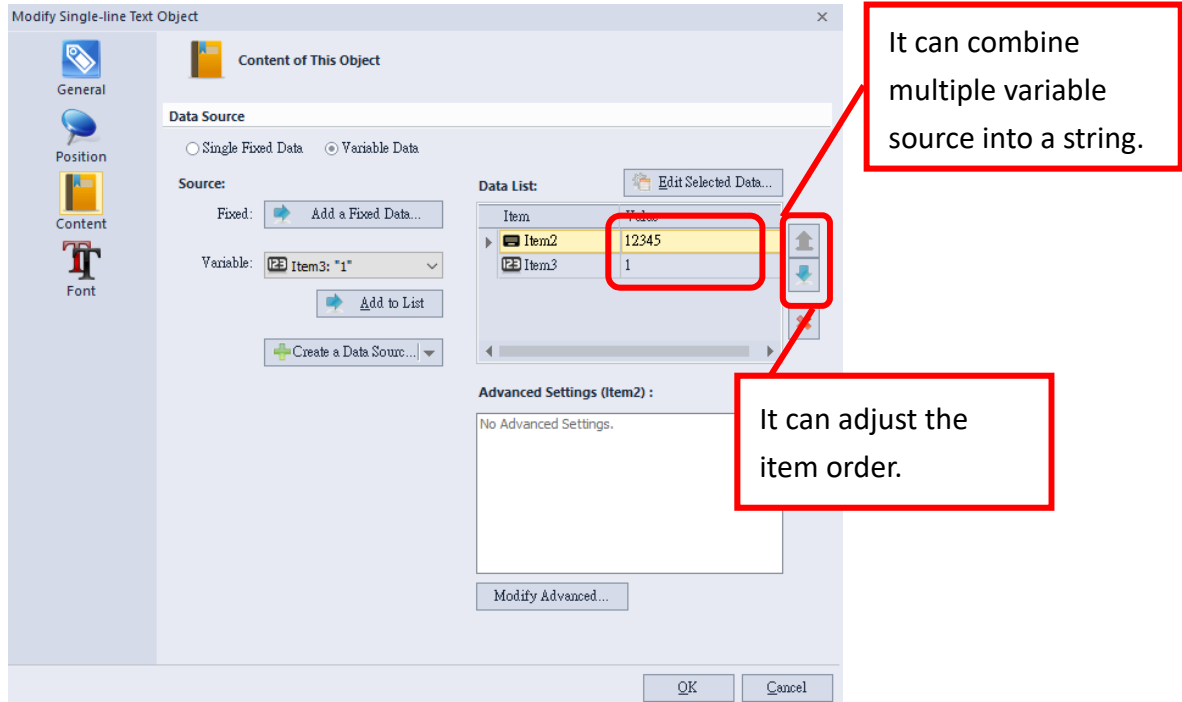

23) Follow the above procedure and finish the below example.

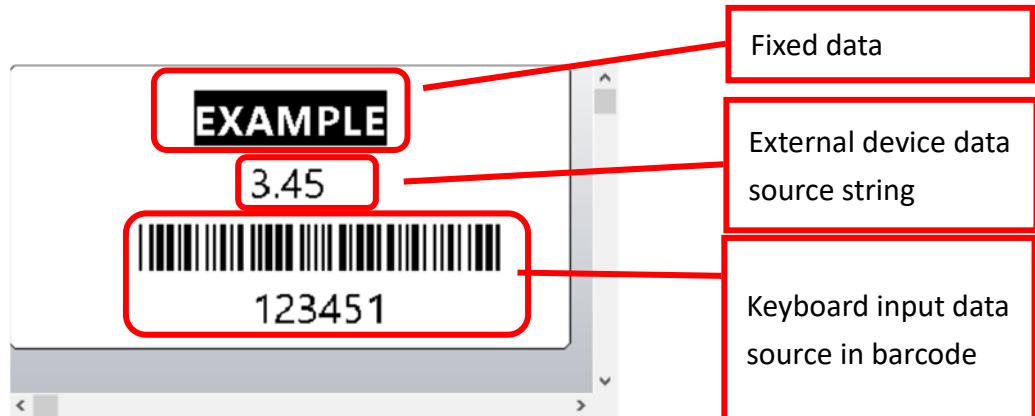

24) Finally, we produce the following sources of information ◦

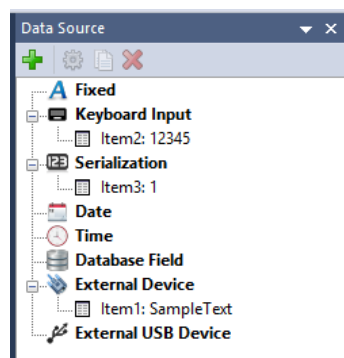

## 8.5 How to download the file to the printer

- 1) Click "Print" in the print function.

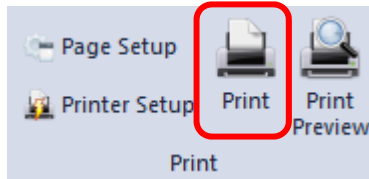

- 2) The dialog set forth various information needs to be set, and the way which is downloaded to the printer.

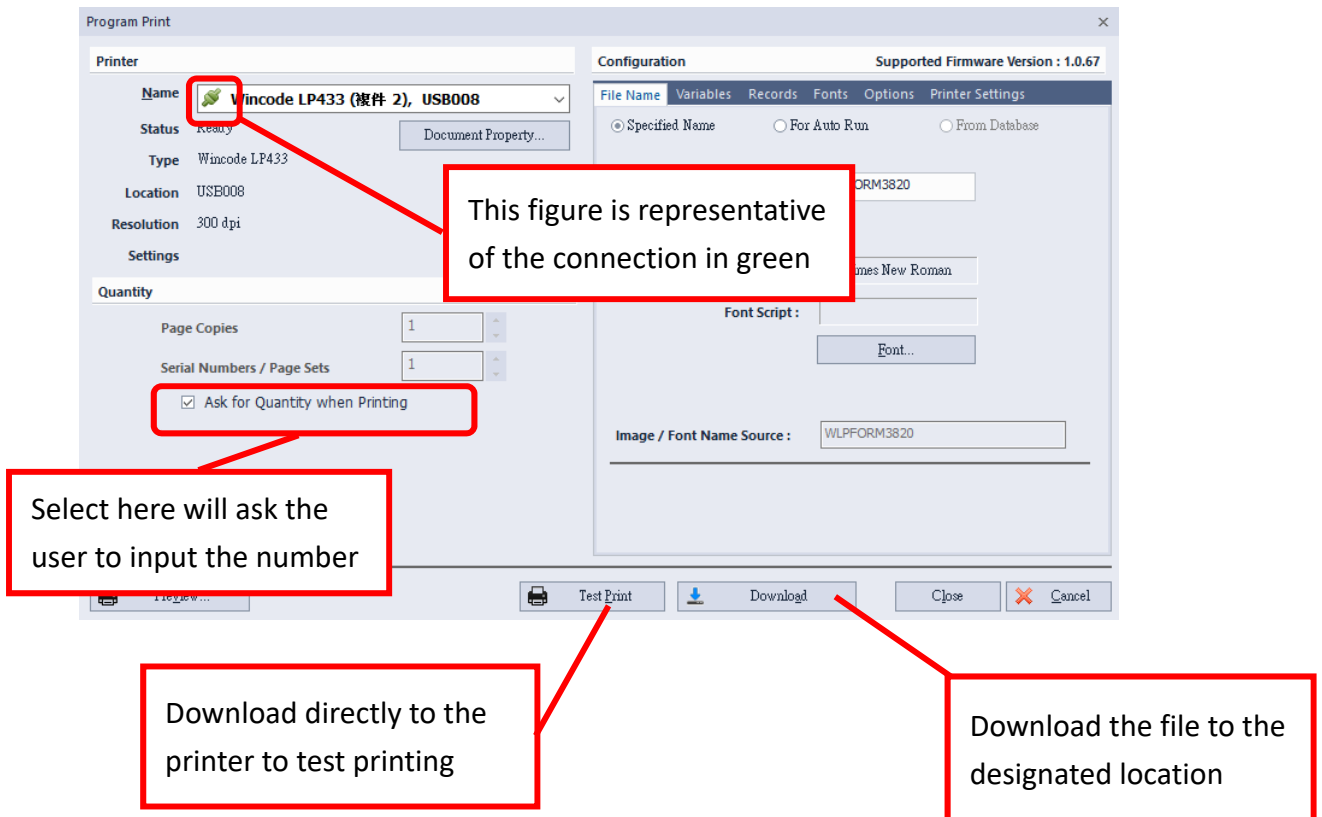

The screenshot shows the 'Program Print' dialog box. The 'Printer' section is highlighted with a red box, and a callout box points to it with the text: "This figure is representative of the connection in green". The 'Quantity' section has a checkbox labeled 'Ask for Quantity when Printing' which is checked, and a callout box points to it with the text: "Select here will ask the user to input the number". At the bottom, there are two 'Download' buttons: 'Test Print' and 'Download'. Callout boxes point to these buttons with the following text: "Download directly to the printer to test printing" and "Download the file to the designated location".

3) File name: set the output file name.

- There are three types of file name, first is specify the name, second is automatically perform the name after boot up, the last is if the objection have database, you can output files through the database, and as a file name basis.
- Users can modify the font and language of the file name, such as Thai output in Chinese.

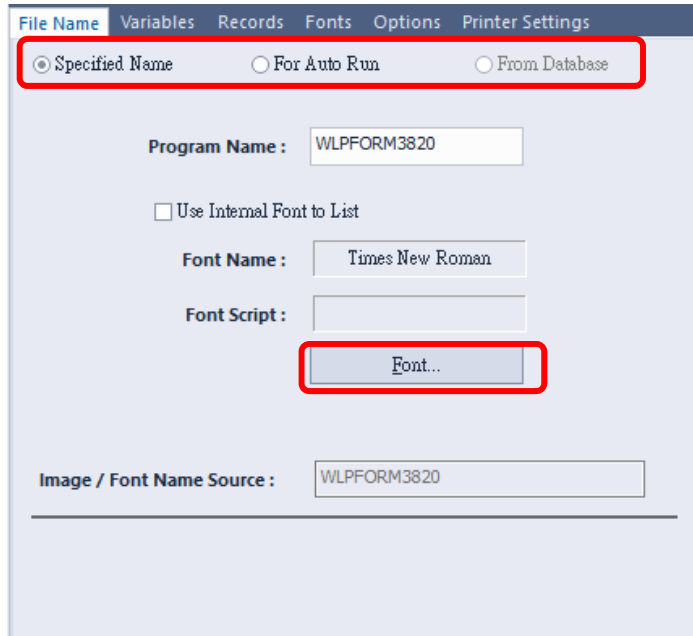

4) Variables: List all the items have data source. It can adjust the input order.

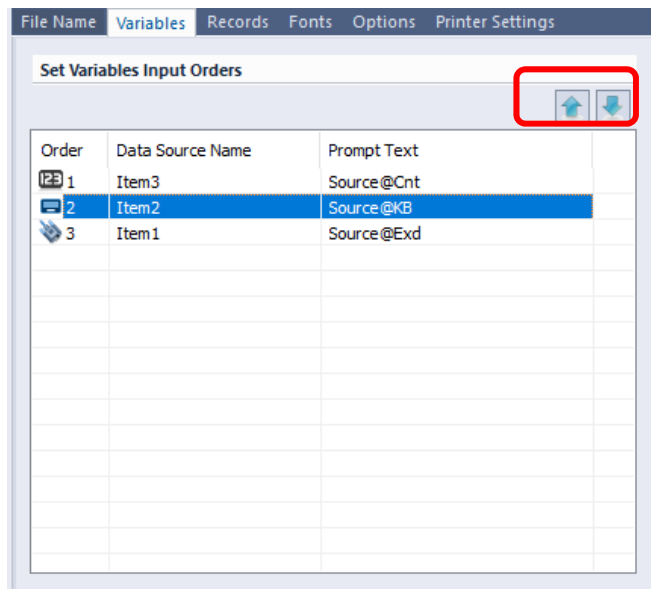

- 5) Records: printing information can be saved in the SD card, and the information can be used as Big Data Analysis. Check “Enable record” and select item which you want to be record in the left column “Available Records”. The right column show the selected record.

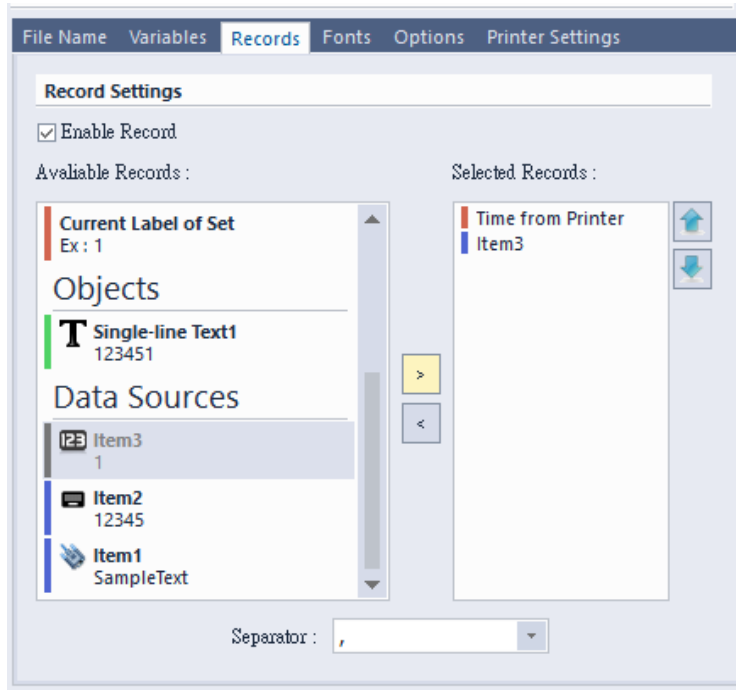

- 6) Fonts: The system will automatically generate all the font sources when the layout object is variable data. Because of the limited memory of printer, it cannot download every font at the same time. It can adjust the font range, select the font to reduce the space of memory, so that the file can be loaded and executed smoothly.

The list of font ranges as below:

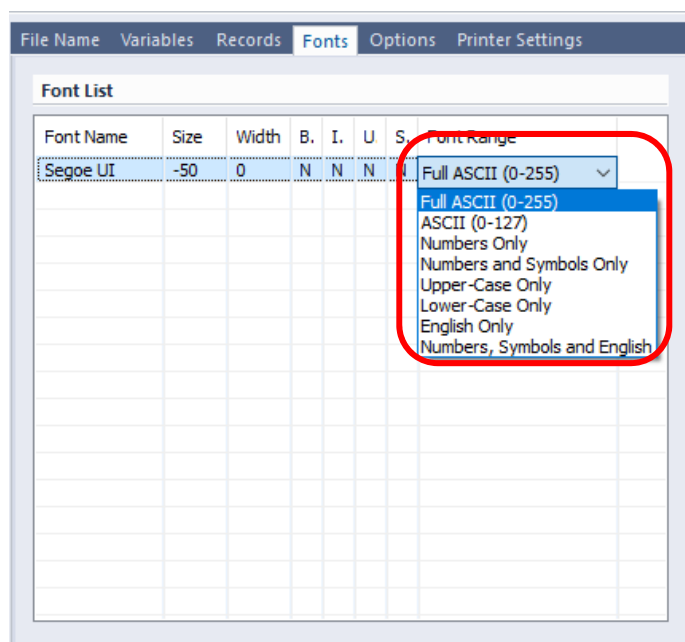



- 7) Options: Provide stand-alone execution period will demand function. After printing, no longer return to the file list, it returns to the beginning of this file to continue.



- 8) Printer Settings: Users can set the printer depend on practical needs. The setting will save in the file.

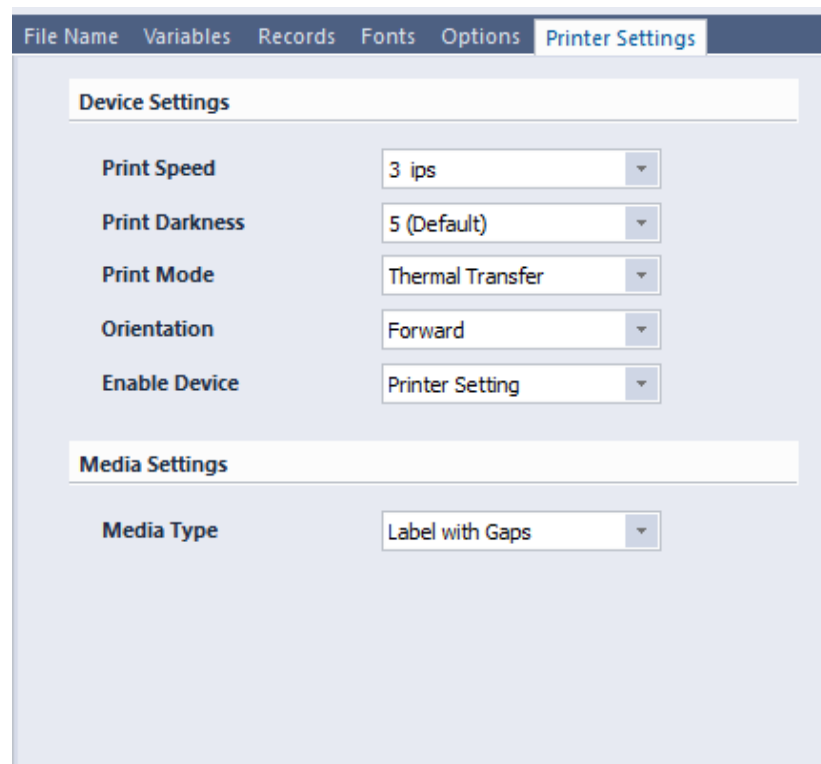

- 9) Click the “download” button, it will ask users where the file output to the printer.
- RAM Disk: Typically used for testing. When the power off, the file will disappear.
  - Flash ROM: The file won’t disappear when the power off. Typically used for small file and no need to use SD card.
  - SD Card: You can store large number of files but the SD card needs to be FAT32 format and build a folder” WPL\_Stuff” to save the files. It also can put in the printer, the printer will automatically create folders.

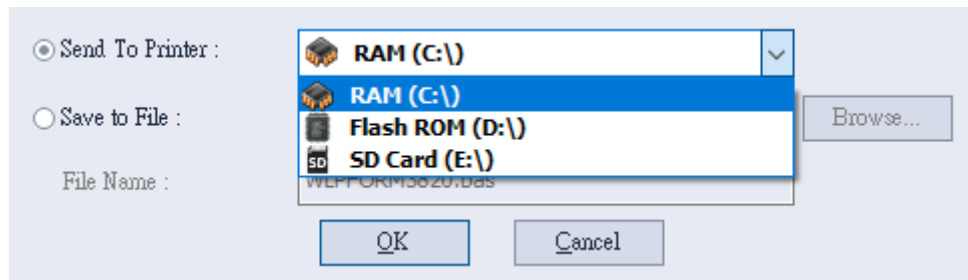

- 10) Click “Download” button and select” Save to File”. It will output the file to the specified storage location.

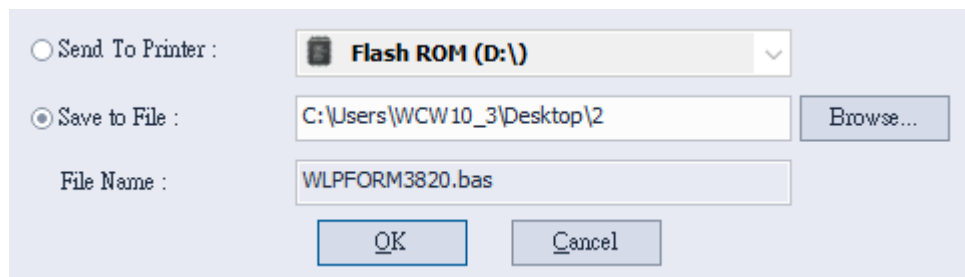

11) When the output or download is finished, it will be appeared the below dialog, to let the users know the output file destination information and queries.

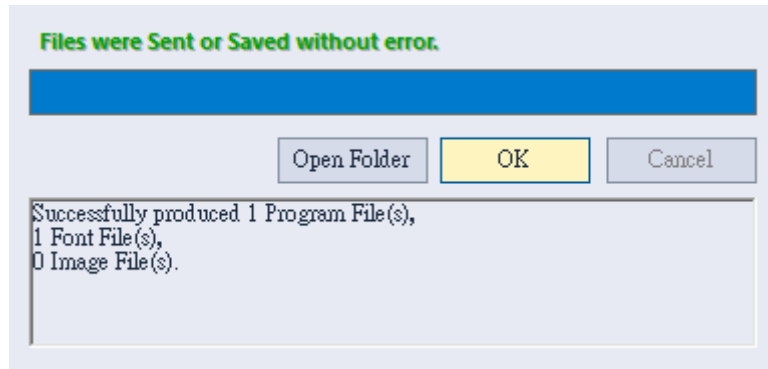

12) Searching SD card after processed by the printer. You can find a folder "WPL Stuff", this folder stores all the standalone files where all the stand-alone operation will be listed.

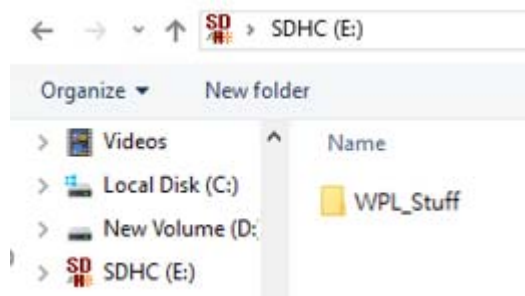

13) The file type of standalone operation

File extension	Application
*.bas	BASIC program file
*.fnt	Standalone font resource files
*.pcx	Standalone font graphics files

## 8.6 How to execute standalone file



The device is ready



SD card into the printer



Main menu: Check built-in clock, USB keyboard, and SD card.



Press menu button, enter "APPLICATION".

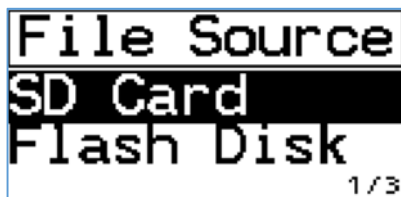

Select SD card.



Select the file to execute.



"Keyboard input" input the data by USB keyboard.



"Serial number" input the initial value by USB keyboard.

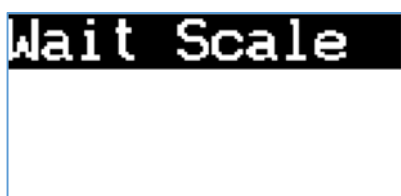

"External device" input by RS-232 device.

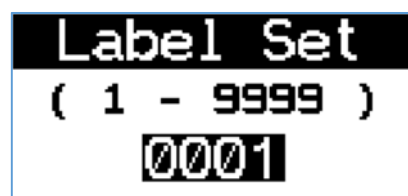

Label set: when you use serial number, users will be required to enter.



Label copies setting: It will display before the software download the file, select “prompt to enter quantity when print

Print results

## 8.7 Actual cases using standalone operation

- 1) Connect to keyboard: For baking industry, north-south goods... etc.



- 2) Connect to keyboard and RS-232 scanner: For library complement label, online job labeling... etc.





















- 3) Connect numeric keyboard and electronic scale: For Agriculture, Fisheries and Livestock, Metal manufacturing...etc.



## 9. General Keypad correspondence

Keypad Map	Name	Function
	Window	Menu Enter
	Escape	Menu Exit
	Enter	Enter
	Arrow Down	Down
	Arrow Left	Up
	Arrow Right	Down
	Arrow Up	Up
	Caps Lock	Capital switch
	Delete	Delete
	Back Space	Back Space
	NumLock	Please review the numeric keypad correspondence

## 10. Numeric Keypad Correspondence

Numeric Keypad Map	Name	Name
	/	/
	*	*
	-	-
	+	+
	Enter	Enter
	1 / End	1
	2 / Arrow Down	2
	3 / PgDn	3
	4 / Arrow Left	4
	5	5
	6 / Arrow Right	6
	7 / Home	7
	8 / Arrow Up	8
	9 / PgUp	9
	0 / Ins	0
	. / Del	.
	000	000
	Back Space	Back Space



## 11. Maintenance

The following are some steps and methods to suggest user for proceeding the simple maintenance of the printer.

1. Turn off the power firstly, and then open the top cover of printer.
2. Take out the ribbon then find the print head. (If the print job has just finished, please wait until it is completely cool.)
3. If the print head is adhibited with label paper or dirt, please use a head cleaning pen or a cotton swab with 100% ethanol to clean the surface of the print head. Repeat the procedure until it is all cleaned.
4. Keep the regular rubber roller cleaning to maintain the printing quality and avoid the print head damage.
5. Use compressed air or vacuum to clean the dirt from the sensor.

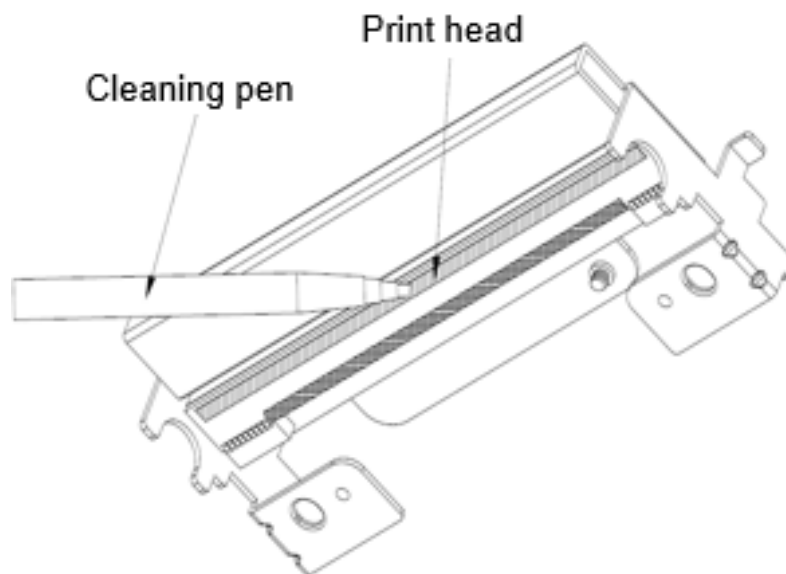

Note:

- 1.) it is suggested to clean the printhead once a week and to clean the sensor once a month.
- 2.) When using a cotton swab to clean the print head, please make sure that there are no metal fragments or hard particles attached on the cotton swab as that would cause the damage of the print head.

## 12. Appendix – LP4A series specification

Model	LP423A	LP433A
Printing method	Thermal Transfer / Direct Thermal	
Resolution	203 DPI	300 DPI
Max. print speed	127 mm (5") / second	102 mm (4") / second
Max. print width	108 mm (4.25")	109.77 mm (4.32")
Max. print length	4572mm (180")	2032mm (80")
Enclosure	Double-walled plastic	
Physical dimension	220mm(W)x198mm(H)x288mm(D)	
	8.7"(W)x7.8"(H)x11.3"(D)	
Weight	2.5 KG	
Label roll capacity	127 mm (5")OD	
Ribbon	300M length, max. OD 67 mm, 1" core	
	100M length, max. OD 38.25 mm, 0.5" core	
Ribbon width	25.4 mm ~ 110 mm (1" ~ 4.3")	
Processor	32-bit RISC CPU	
Memory	8MB Flash memory, 16MB SDRAM, SD slot for expansion up to 32GB	
Power	External universal switching power supply, Input: AC 100-240V, 2.0A, 50-60Hz, output: DC 24V, 2.5A, 60W	
Operation interface	4 buttons, 2 LEDs, 1 LCD (2.13" Resolution :128x64), 1 Buzzer	
Interface	USB 2.0, RS-232, USB Host, Parallel	
	Bluetooth(option), WIFI IEEE 802.11 b/g/n (option), Ethernet 10/100 Mbps (option)	
Sensors	Transmissive gap sensor (adjustable), Reflective gap sensor, Ribbon end sensor, Head open sensor, Paper near end sensor(option)	
Internal fonts	Seven kinds of bitmap fonts	
Bar code	1D bar code : Code 11, Code 39, Code 93, Code 128, Codabar, EAN/JAN-8, EAN/JAN-13, Interleaved 2-of-5, ITF-14, MSI Pleassy, PostCode, Telepen, UPC-A, UPC-E, UCC-128	
	2D bar code : Code 16K, Code 49, Aztec Code, QR Code, PDF417, Micro PDF417, Data Matrix, Grid Matrix, Micro QR Code, MaxiCode	
Printer language	WPL (ZPL, EPL, TSPL, DPL...auto switch)	
Dealer options	Cutter 、Peeler Dispenser 、External label stand	
Media width	Standard :15 ~ 120 mm (0.59" ~ 4.72")	
	With Cutter: 15~117mm (0.59" ~ 4.61")	
	External Label Stand: 15 ~ 115mm (0.59" ~ 4.53")	
Media thickness	0.06 ~ 0.19 mm (2.36 ~ 7.48 mil)	
Media core diameter	25.4 mm (1")	
Label length	3 ~ 4,572 mm (0.12" ~ 180")	3 ~ 2,032 mm (0.12" ~ 80")
Real time clock	RTC (battery is included)	
Safety regulation	CE Class A, FCC Class A, CB	
Bundled software	WinLabel labelling application, windows printer driver, printer utility, DLL SDK library, EXE executive AP for batch print. Platform support: Windows Vista, 7, 8, 8.1, 10, 11 and Server 2003, 2008, 2012, 2012R2 (32/64 bit)	

Made in Taiwan.

Features and specifications are subject to change without prior notice.

**WINCODE TECHNOLOGY CO.,LTD**

Add:13F.,No.219,Sec.3,Beixin Rd.,Xindian Dist.,New Taipei City 231,Taiwan(R.O.C)

[Tel:+886-2-2917-1759](tel:+886-2-2917-1759)

Website:[www.wincodetek.com](http://www.wincodetek.com)